

Operating instructions

Coffee machine



To avoid the risk of accidents or damage to the appliance it is **essential** to read these instructions before it is installed and used for the first time.

Caring for the environment

Packaging material

The packaging material used protects the machine during transportation. Please retain the original box and polystyrene pieces so that you can pack the machine securely, should you need to transport it in the future.

Disposal of the Miele descaling cartridge

Dispose of the used Miele descaling cartridge in your household waste.

Disposing of your old appliance

Electrical and electronic appliances often contain valuable materials. They also contain specific materials, compounds and components, which were essential for their correct function and safety. These could be hazardous to human health and to the environment if disposed of with your domestic waste or if handled incorrectly. Please do not, therefore, dispose of your old appliance with your household waste.

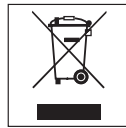

Please dispose of it at your local community waste collection / recycling centre for electrical and electronic appliances, or contact your dealer or Miele for advice. You are also responsible (by law, depending on country) for deleting any personal data that may be stored on the appliance being disposed of. Please ensure that your old appliance poses no risk to children while being stored prior to disposal.

Caring for the environment	2
Warning and Safety instructions	7
Guide to the machine	17
Rear of machine	18
Unpacking and installing	20
Unpacking the coffee machine	20
Accessories supplied	20
Setting up and connecting the coffee machine	20
Operation	22
Touch display	22
Operation.....	22
Symbols in the display	24
Before using for the first time	26
Fit the descaling cartridge.....	26
Setting the water hardness level	27
Filling the water container	29
Filling the coffee bean container	30
Switching on and off	31
Spout adjustment	32
Cup heating	33
Making coffee	34
Making a coffee.....	34
Cancelling preparation	34
DoubleShot.....	35
Making two portions ☐	35
Coffee pot: making several cups of coffee one after the other	35
Making coffee with milk	38
Using the milk flask	39
Using milk cartons or bottles	40
Making drinks with milk.....	40
Cancelling a drink.....	40
Tea	41
TeaTimer	41

Contents

Making tea.....	42
Cancelling tea preparation	42
Tea pot: making several cups of tea, one after the other	42
Dispensing hot water	44
Parameters	45
Ground quantity.....	45
Brewing temperature	45
Pre-brewing the coffee	45
Grinder setting.....	46
Portion size	47
Resetting drinks	48
Profiles	49
Creating a profile	49
Opening the Profiles menu and selecting a profile.....	49
Processing profiles	49
Profiles: creating and processing drinks	51
Profiles: making drinks	52
Expert mode	53
Settings	54
Opening the Settings menu.....	54
Changing and saving settings	54
Possible setting options	55
Language.....	58
Time.....	58
Timer	58
Switch on at	59
Switch off at	59
Switch off after	59
Allocating days of the week	59
Eco mode	59
Lighting.....	60
Water hardness	60
Info (display information)	60
Locking the coffee machine (System lock )	61
Miele@home.....	61
Display brightness.....	61

Volume.....	61
Service.....	61
Evaporate	61
Demo mode.....	61
Factory default.....	62
Network configuration	62
Networking.....	63
Setting up the network (Miele@home).....	63
Setting up the network again	64
Remote control.....	64
MobileStart	65
RemoteUpdate	66
Cleaning and care	67
Overview of cleaning intervals.....	67
Cleaning by hand or in the dishwasher	68
Unsuitable cleaning agents	69
Clean the drip tray and waste container	70
Cleaning the drip tray cover	71
Cleaning the water container	72
Removing and cleaning the water container filter	72
Cleaning the central spout with integrated cappuccinatore.....	73
Removing and cleaning the cup sensor	74
Cleaning the stainless steel milk flask.....	75
Cleaning the milk pipework manually or using the maintenance programme	75
Clean the bean container	76
Ground coffee drawer cleaning	76
Cleaning the housing.....	77
Maintenance programmes.....	77
Rinsing the machine.....	78
Rinsing the milk pipework	78
Cleaning the milk line	79
Degreasing the brew unit and cleaning inside	80
Descaling the machine	82
Automatic descaling	85
Please note before and during automatic descaling:.....	85
The Miele descaling cartridge	86
Fitting and removing a descaling cartridge.....	87
Set the start time for automatic descaling (Descaling timer).	88
Problem solving guide	89
Messages in the display	89

Contents

Unusual performance of the coffee machine	92
Faults with automatic descaling	96
Unsatisfactory results.....	97
After sales service and warranty	99
Contact in case of malfunction	99
Warranty	99
Transporting the machine	100
Evaporate	100
Packing the machine.....	101
Accessories	102
Saving energy	103
Mains connection cable	104
Conformity declaration	105
Dimensions	106
Technical data	107
Conformity declaration	108

Warning and Safety instructions

This coffee machine complies with current safety requirements. Improper use can, however, present a risk of both personal injury and material damage.

To avoid the risk of accidents and damage to the machine, please read these instructions carefully before using it for the first time.

They contain important notes on setting it up, as well as on its safety, operation and maintenance.

Miele cannot be held liable for damage caused by non-compliance with these Warning and Safety instructions.

Keep the instructions in a safe place and pass them on to any future owner.

Warning and Safety instructions

Correct application

- ▶ This coffee machine is intended for use in domestic households and similar working and residential environments. Examples of a working or residential environment include
 - shops, offices and other working environments,
 - small businesses, showrooms etc.,
 - where the coffee machine is being used by customers in hotels, motels, bed and breakfast and other similar establishments.
- ▶ It must only be used as a domestic appliance to make espresso, cappuccino, latte macchiato, tea etc. Any other use is not permitted.
- ▶ This coffee machine is not intended for outdoor use.
- ▶ This coffee machine must not be used at altitudes above 2000 m.
- ▶ This coffee machine can only be used by people with reduced physical, sensory or mental capabilities, or lack of experience and knowledge, if they are supervised whilst using it, or have been shown how to use it in a safe way and recognise and understand the consequences of incorrect operation.

Safety with children

 Danger of burning and scalding on the dispensing spouts. Children's skin is far more sensitive to high temperatures than that of adults.

Ensure children do not touch hot surfaces of the coffee machine or place parts of their body under the dispensing spouts.

- ▶ Install the coffee machine where it is out of the reach of children.
- ▶ Children under eight years of age must be kept away from the machine and the mains connection cable and plug/socket.
- ▶ Children 8 years and older may only use the coffee machine unsupervised if they have been shown how to use it safely and recognise and understand the consequences of incorrect operation.
- ▶ Please supervise children in the vicinity of the coffee machine and do not allow them to play with it.
- ▶ Young children must not be allowed to clean the coffee machine unsupervised. Cleaning may only be carried out by children eight years of age or older under the supervision of an adult.
- ▶ Remember that coffee and espresso are not suitable drinks for children.
- ▶ Danger of suffocation! Whilst playing, children may become entangled in packaging material (such as plastic wrapping) or pull it over their head with the risk of suffocation. Keep packaging material away from children.

Warning and Safety instructions

Technical safety

- ▶ A damaged coffee machine is dangerous. Check it for any visible damage before setting it up. Never attempt to use a damaged coffee machine.
- ▶ To avoid the risk of damage to the machine, make sure the connection data (voltage and frequency) on the data plate corresponds to the household supply, before connecting the machine to the mains supply. Consult a qualified electrician if in any doubt.
- ▶ The electrical safety of this coffee machine can only be guaranteed when correctly earthed. It is essential that this standard safety requirement is met. If in any doubt please have the electrical installation tested by a qualified electrician.
- ▶ Reliable and safe operation of the coffee machine can only be guaranteed if it is connected to the mains electrical supply.
- ▶ Do not connect the machine to the mains electricity supply by a multi-socket adapter or an extension lead. These are a fire hazard and do not guarantee the required safety of the appliance.
- ▶ The coffee machine must not be used in a non-stationary location (e.g. on a ship).
- ▶ Unplug the machine from the power supply immediately if you notice any damage or smell scorching, for example.
- ▶ Ensure that the mains connection cable cannot be pinched or damaged by any sharp edges.
- ▶ The mains connection cable should not hang down. Someone could trip over it with the risk of injury and damage the machine.
- ▶ Only use the coffee machine in rooms where the ambient temperature is between +16 °C and +38 °C.

Warning and Safety instructions

- ▶ Do not place the coffee machine near a window in direct sunshine or right next to an appliance that gives off heat. These would subject the machine to ambient temperatures outside its permitted operating range.
- ▶ Position the coffee machine at a height of at least 850 mm from the floor.
- ▶ Danger of overheating. Please ensure that there is adequate ventilation around the coffee machine. Do not cover the coffee machine with tea towels etc. while it is in use.
- ▶ The coffee machine must not be installed in a niche. Heat and moisture can accumulate in a niche. This can result in damage to the appliance and/or furniture unit.
- ▶ Protect the coffee machine from water and water spray. Do not immerse the machine in water.
- ▶ Repairs and other work by unqualified persons to the machine and the connection cable could be dangerous. The manufacturer cannot be held liable for unauthorised work. Repairs may only be carried out by a Miele authorised service technician.
- ▶ While the machine is under warranty, repairs should only be undertaken by a Miele authorised service technician. Otherwise the warranty is invalidated.
- ▶ Miele can only guarantee the safety of the appliance when genuine original Miele replacement parts are used. Faulty components must only be replaced by genuine Miele original spare parts.
- ▶ The coffee machine must be disconnected from the electricity supply during repair work.
- ▶ Never open the outer casing of the machine. Tampering with electrical connections or components and mechanical parts is highly dangerous to the user and can cause operational faults or electric shock.

Warning and Safety instructions

▶ Only use genuine original Miele accessories with this machine. Using spare parts or accessories from other manufacturers will invalidate the guarantee, and Miele cannot accept liability.

Warning and Safety instructions

Correct use

 Danger of burning and scalding on the dispensing spouts. The liquids and steam dispensed are very hot.

Keep well away from the area underneath the spouts when hot liquids and steam are being dispensed.

Do not touch hot components.

Hot liquid or steam could spatter from the spouts. Ensure that the central spout is clean and fitted correctly.

Water in the drip tray can also be very hot. Take care when emptying it.

 Danger of injury to the eyes.

Never look directly at the lighting or use optical instruments to look at it.

▶ Please note the following regarding water:

- The water quality must conform to the requirements for drinking water in the country in which the coffee machine is being used.
- Only use cold, fresh tap water to fill the water container. Hot or warm water or other liquids can damage the coffee machine.
- Change the water every day to prevent a build-up of bacteria.
- Do not use carbonated water.

▶ Only fill the bean container with roasted espresso/coffee beans. Do not fill the bean container with coffee beans which have been treated with additives or with ground coffee.

▶ Do not fill the bean container with any type of liquid.

▶ Do not use green (unroasted) coffee beans or mixtures of coffee beans which contain green coffee beans. Green coffee beans are very hard and still contain residual moisture. These can damage the coffee machine grinder as soon as grinding begins.

Warning and Safety instructions

- ▶ Do not use coffee beans which have been treated with caramel, sugar or other substances including sugary liquids. Sugar will damage the coffee machine.
- ▶ Only fill the coffee chute with ground coffee beans.
- ▶ Do not use any caramelised ready ground coffee. The sugar in the coffee will stick to and block the brew unit of the coffee machine. The cleaning tablets for degreasing the brew unit will not remove this type of deposit.
- ▶ Only use milk without additives. Additives in milk usually contain sugar and this will stick to the milk pipework.
- ▶ If using dairy milk make sure that it has been pasteurised.
- ▶ When making tea, please follow the instructions on the packaging.
- ▶ Do not place any alcohol mixtures which are alight underneath the central spout. The flames could ignite plastic components and cause them to melt.
- ▶ Do not use naked flames, e.g. a candle, on or near the coffee machine. The coffee machine could catch fire with the risk of the fire spreading.
- ▶ The machine must not be used for cleaning objects.

Cleaning and care

- ▶ Clean the coffee machine and the milk flask daily, particularly before using for the first time.
- ▶ All parts of the milk system need to be cleaned thoroughly and regularly. Milk contains bacteria which proliferate rapidly with inadequate cleaning.
- ▶ Do not use a steam cleaner to clean this machine. Steam could reach electrical components and cause a short circuit.
- ▶ If you do not utilise automatic descaling, you will need to descale the coffee machine manually on a regular basis. Miele cannot be held liable for damage resulting from not descaling the machine, using the wrong descaling agent or an unsuitable descaling solution concentration.
- ▶ Degrease the brew unit regularly with Miele cleaning tablets. Depending on the natural oil content of the coffee used, the brew unit can become blocked quite quickly.
- ▶ Used coffee grounds should be disposed of with the organic rubbish or on the compost heap. Do not empty them down the sink, as they could block it.

Warning and Safety instructions

For machines with stainless steel surfaces:

- ▶ Do not use sticky notes, transparent adhesive tape, masking tape or other types of adhesive on the stainless steel surfaces.
- ▶ Stainless steel surfaces are susceptible to scratching. Even magnets can cause scratches.

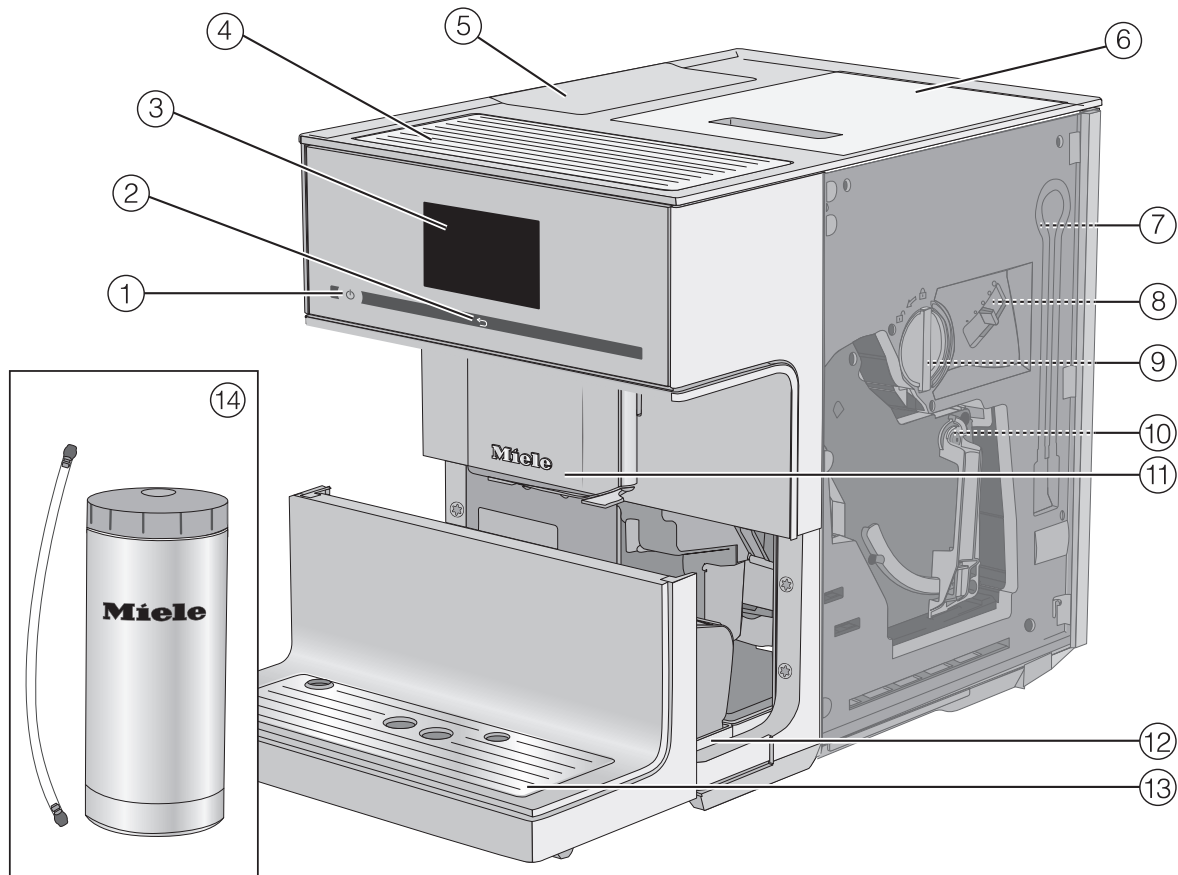

- ① On/Off button ①
- ② "Back" ← sensor
- ③ Touch display
- ④ Cup heating
- ⑤ Water container
- ⑥ Bean container
- ⑦ Park position for milk tube
- ⑧ Grinder setting
- ⑨ Ground coffee drawer with integrated coffee scoop
- ⑩ Brew unit
- ⑪ Height-adjustable central spout with lighting
- ⑫ Drip tray with lid and waste container
- ⑬ Lower panel with drip tray cover
- ⑭ Stainless steel milk flask with milk tube

Guide to the machine

Rear of machine

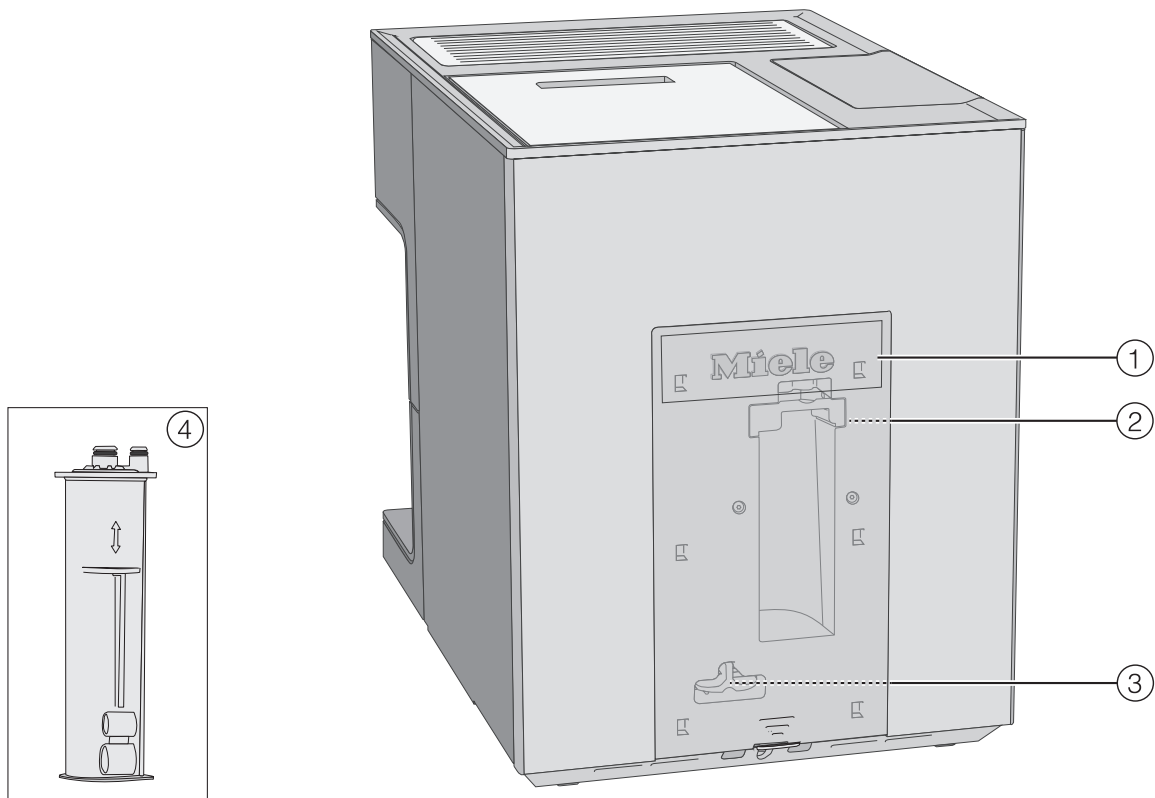

- ① Cover
- ② Descaling cartridge holder
- ③ Adapter
- ④ Miele descaling cartridge

Central spout in detail

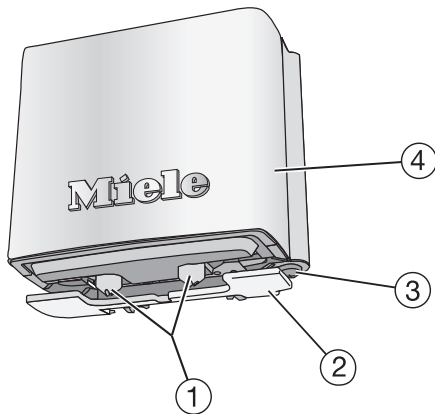

- ① Dispensing spouts for coffee and milk
- ② Cup sensor
- ③ Hot-water spout
- ④ Stainless steel cover

Unpacking and installing

Unpacking the coffee machine

- Unpack the coffee machine.
- Remove any protective foil and notes from the machine.

Tip: Please retain the original box and polystyrene pieces so that you can pack the machine securely, should you need to transport it in the future.

The drip tray cover can be found in the accessories pack.

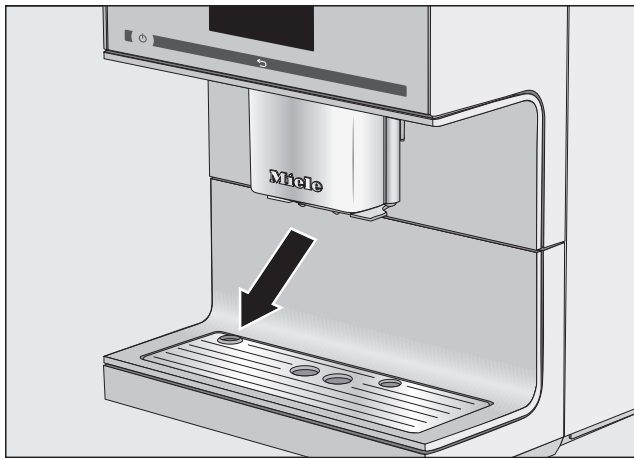

- Remove the protective foil from the drip tray cover and place the drip tray cover into the lower panel.

Accessories supplied

The following accessories are included with your coffee machine:

- Stainless steel milk flask MB CM (capacity 0.5 l)
- Milk pipework (suitable for use with the milk flask and with milk cartons or similar)
- Cleaning tablets for degreasing the brew unit (starter set)
- Miele descaling tablets (starter set)
- Miele descaling cartridge

- Cleaning brush

Setting up and connecting the coffee machine

⚠ Danger of overheating due to insufficient ventilation.

If the coffee machine is not sufficiently ventilated, the appliance can overheat.

Please ensure that there is adequate ventilation around the coffee machine.

Do not cover the coffee machine with tea towels etc. while it is in use.

If the coffee machine is installed in a niche, heat and moisture will accumulate inside the niche. This can result in damage to the coffee machine and/or furniture unit.

Do not install the appliance in a niche.

Please observe the following installation instructions:

- The location of the machine must be dry and well ventilated.
- The ambient temperature of the room in which the machine is used must be between 16 °C and 38 °C.
- Do not place the coffee machine near a window in direct sunshine or right next to an appliance that gives off heat. These would subject the machine to ambient temperatures outside its permitted operating range.
- The coffee machine must be set up on a level surface. The surface must be water resistant.

Unpacking and installing

- The appliance door must be opened completely to remove the brew unit.
- Place the coffee machine in the location you want to use it.
- Clean the appliance thoroughly before filling it with mains tap water and coffee beans.
- Insert the plug of the coffee machine into the socket (see “Electrical connection”).
- Remove the water container and fill it with fresh, cold tap water. Only fill the water container up to the “max.” marker and then refit it in the machine.
- Take the lid off the coffee bean container, fill it with roasted coffee beans and replace the lid.

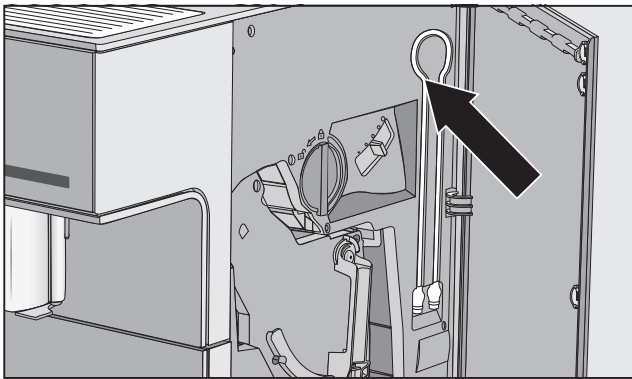

Tip: The milk pipework can be stored behind the service panel when not in use.

Operation

Touch display

The touch display can be scratched by pointed or sharp objects, e.g. pens.
Only touch the display with your fingers.

If your fingers are cold, the Touch display may not react.

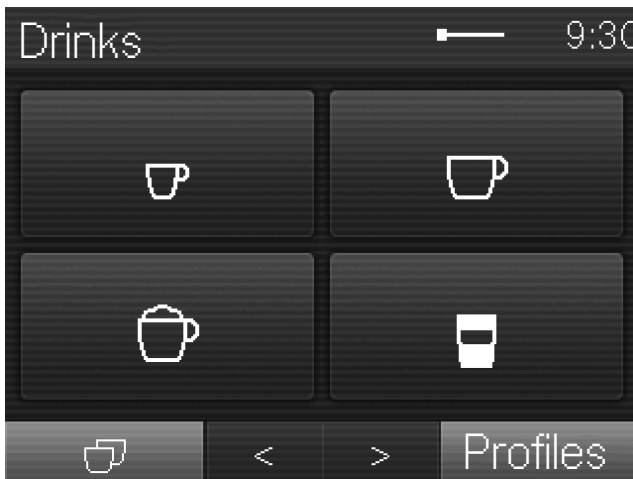

The display is split into three sections.

The menu name is displayed in the top left and the time in the top right of the display. Depending on the number of items in the menu, a scroll bar may also appear in the middle.

The middle row shows the current menu and options. The most popular drinks are depicted with symbols in the Drinks menu (see "Symbols in the display" for an explanation of the symbols).

You can scroll to the right or left using the < and > arrows at the bottom of the display. Context-dependent functions and menus can be found to the left and right of the arrow sensors.

Operation

You can only select options which are highlighted in light grey.

Each time you touch a possible option the relevant field lights up partially or completely **orange**.

Selecting or opening a menu

- Touch the field you want with your finger.

Scrolling

You can scroll left or right using the < and > arrow sensors.

- Touch the arrow sensor for the direction you want to go.

Exiting a menu ("Back" ← sensor)

- Touch the ← sensor to return to the previous screen.

Entries made before this which have not been confirmed with *OK* will not be saved.

Entering numbers

Use the numerical keypad to enter numbers, e.g. if you want to set a timer duration. The numerical keypad will appear automatically in the relevant menus.



- Touch the numbers you want.

Once you have entered an accepted value, the *OK* field will light up green.

- Touch *OK*.

You can delete one character at a time using the arrow sensor.

Entering letters

Profile names or the names for your own drinks are entered using a keyboard.

It is best to select short names (max. 8 characters).

Further letters or symbols can be accessed using the < and > arrow sensors. Numbers can be found by touching the 123 sensor.

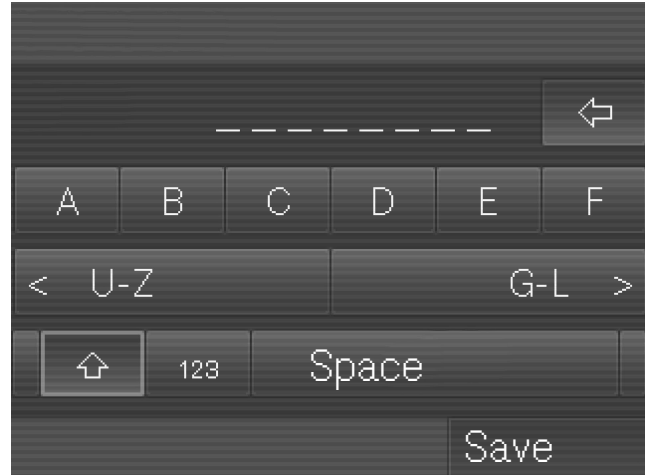















- Select the letters or characters you want.
- Touch *Save*.

Operation

Symbols in the display

The following symbols may also appear in the display in addition to the text:

Symbol	Explanation
	This symbol indicates the “Settings” menu and the “Language” menu option.
	Some settings, e.g. display brightness and buzzer/keypad volume, are selected using a bar chart.
	This symbol indicates that there is additional information and advice about using the coffee machine. Select <i>OK</i> to confirm the information.
	The Switch on at is activated (see “Settings - Timer”). The symbol and the desired switching on time appear in the display 23:59 hours before the coffee machine is due to switch on, as long as On or Night dimming is selected for the time display.
	The TeaTimer minute minder has been started (see “TeaTimer”). The remaining brewing time is shown next to the symbol.
	This symbol appears if the system lock is activated. Operation is locked.
	This symbol appears while the appliance is being descaled. (This symbol can also be found on the water container: fill up to this mark).
	This symbol appears if you call up the Profiles menu.

Symbol	Explanation
	This symbol and a fault code will appear if a fault occurs.
	The strength of the WiFi connection is shown under Settings Miele@home Connection status. Symbols represent the connection strength in increments from strong to not connected.
	Drinks menu symbols:
	Espresso
	Coffee
	Cappuccino
	Latte macchiato
	Two portions

Before using for the first time

When you connect the machine to the mains power, the following message will appear in the display: Miele - Willkommen.

When you switch the coffee machine on for the first time, you will be prompted to set the following:

- Language and country
- Date
- Time
- Clock display
- Automatic descaling
- Water hardness

■ Touch the On/Off sensor ⓪.

Set the language

- Select the language and touch *OK*.
- Select the country and touch *OK*.

The setting is now saved.

Set the date

- Enter the current date and touch *OK*.

The setting is now saved.

Set the time

- Enter the current time of day and touch *OK*.

The setting is now saved.

Time of clock display setting

You can choose one of the following options:

- On: the time and date are always visible in the display when the machine is switched off.

- Off: the display is dark when the machine is switched off.
- Night dimming: the time and the date are displayed from 5:00 to 23:00.

■ Select clock display and touch *OK*.

Depending on which option you select, the machine may use more energy. A message appears in the display to inform you of this.

Fit the descaling cartridge

Some information about automatic descaling will appear in the display. Further information and instructions can be found in “Automatic descaling” in these operating instructions.

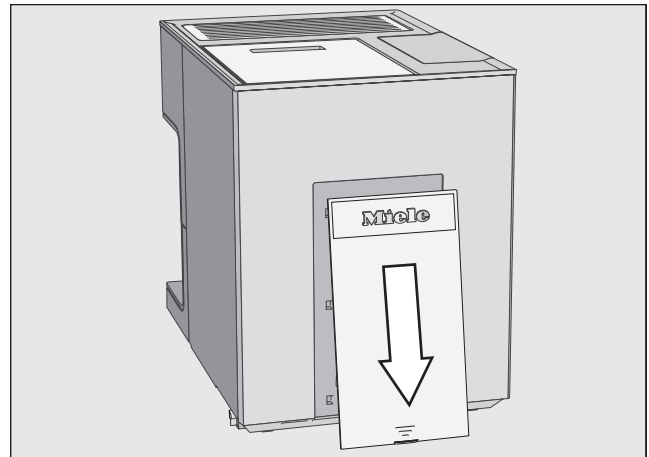

- Remove the cover at the back of the coffee machine.

Before using for the first time

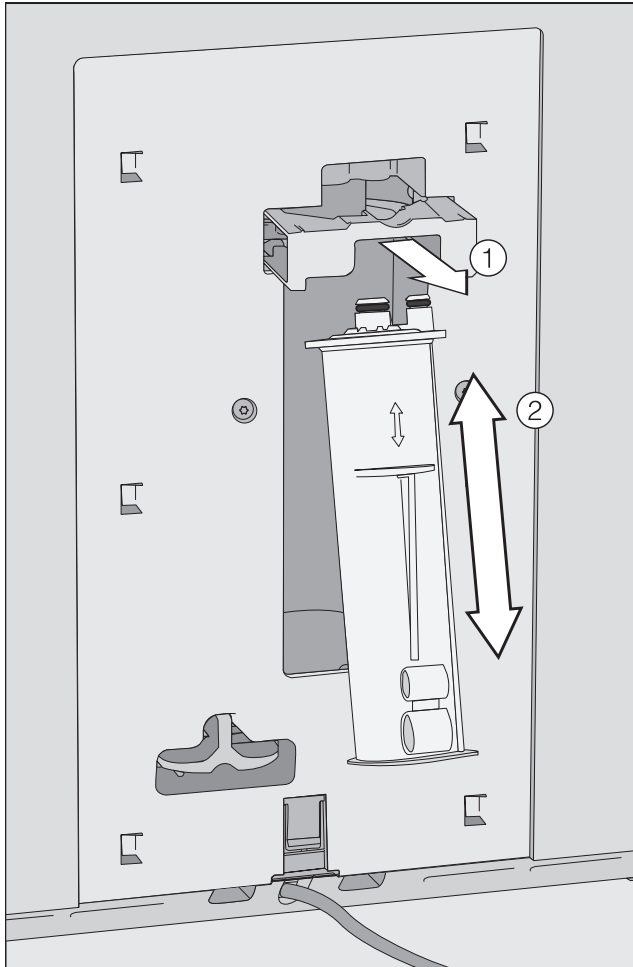

- Pull the cartridge holder ① forwards and insert the descaling cartridge ②. Push the cartridge upwards as far as it will go.
- Push the holder back into position and replace the cover.

The next time the coffee machine is switched off, the descaling cartridge will fill with water. You will hear water being pumped into the cartridge at frequent intervals.

When a descaling cartridge is fitted, a message will appear regarding the current start time set for automatic descaling.

- Touch **OK**.

- If you want to change the start time, touch **Start time** and select the required time.

You can also change the start time for automatic descaling to a later time.

Setting the water hardness level

Contact your local water supplier to find out your local water hardness range if necessary.

The machine has four programmable levels:

°dH	mmol/l	ppm (mg/l CaCO ₃)	Setting*
0 – 8.4	0 – 1.5	0 – 150	Soft
8.4 – 14	1.5 – 2.5	150 – 250	Medium
14 – 21	2.5 – 3.7	250 – 375	Hard
> 21	> 3.7	> 375	Very hard

* The hardness level shown in the display may differ from the hardness level in your area. You **must** follow the values in the chart to set your machine to your local hardness level.

Miele@home communication-enabled appliance appears in the display. You can connect your coffee machine to your local WiFi network (see “Networking”).

- Confirm the message with **OK**.

Your machine has been successfully set up and is ready for use.

Before using for the first time

To ensure that any coffee residues from the factory testing process are removed from the brewing system, please throw away the first two cups of coffee when using the coffee machine for the first time.

After setting the machine up you can make your first drinks. Coffee beans can be ground up to five times, as the coffee machine checks whether there is sufficient ground coffee to make an aromatic cup of coffee, and will grind more beans as necessary.

Filling the water container

⚠ Risk to health due to contaminated water.

Bacteria can develop in water which has been sitting in the water container for too long and is a risk to your health.

Change the water in the water container **every day**.

⚠ Risk of damage due to incorrect operation.

Unsuitable liquids such as hot or warm water or other liquids can damage the coffee machine.

Carbonated water leaves too much limescale in the coffee machine.

Only use cold, fresh tap water to fill the water container.

If the water container is not inserted correctly (e.g. sits too high or at an angle), water can leak from the outlet valve.

Check whether the surface that the water container sits on is soiled. If necessary, clean the surface that the water container sits on.

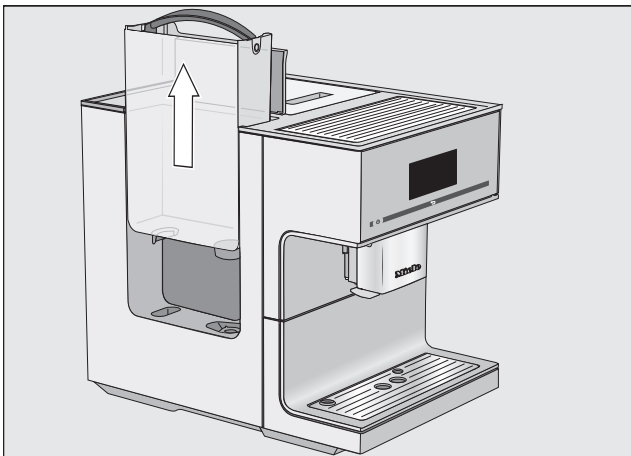

- Open the lid on the left-hand side of the coffee machine.
- Pull the water container up by the handle to remove it.
- Fill the water container with fresh, cold tap water up to the “max.” mark.
- Replace the water container and close the lid.

Filling the coffee bean container

Coffee or Espresso can be made from whole roasted coffee beans which are freshly ground for each portion. This requires the coffee bean container to be filled with coffee beans.

Alternatively, you can make coffee or espresso with ground coffee (see “Making coffee drinks with ground coffee”).

 Risk of damage to the grinder due to incorrect operation.

The coffee machine will be damaged if the bean container is filled with unsuitable substances such as liquids, ground coffee or coffee beans treated with sugar, caramel or similar.

In addition, green (unroasted) coffee beans or mixtures of coffee beans which contain green coffee beans can damage the grinder. Green coffee beans are very hard and still contain residual moisture. These can damage the coffee machine grinder as soon as grinding begins.

Only put roasted coffee beans in the bean container.

Tip: You can use a nut or seed grinder to grind green coffee beans. These types of grinder generally have a rotating stainless steel blade. You can then add the ground green coffee **one portion at a time** to the ground coffee chute and make the desired coffee drink (see “Making coffee drinks with ground coffee”).



- Take the lid off the coffee bean container.
- Fill the container with roasted coffee beans.
- Replace the lid.

Tip: Only add enough beans to last for a few days. Contact with air causes coffee beans to lose their aroma.

Switching the coffee machine on

- Touch the On/Off sensor ①.

The machine heats up and rinses the pipework. Hot water will run out of the central spout.

You can now make drinks.

If the coffee machine is already at operating temperature, rinsing will not take place.

Switching the coffee machine off

- Touch the On/Off sensor ①.

If coffee has been dispensed, the coffee machine will rinse the coffee pipework automatically before switching off.

Switching off for longer periods of time

If the coffee machine is not going to be used for a longer period of time, e.g. if you are going on holiday:

- Empty the drip tray, the waste container and the water container.
- Clean all parts thoroughly, including the brew unit.
- Switch the machine off and withdraw the plug to disconnect it from the power supply.

The time of day set will be saved for a maximum of ten days and after that must be reset. Timer settings, profiles and other settings will be kept.

Spout adjustment

The central spout **cannot** be manually adjusted.

Before making the drink, the central spout moves down and the cup sensor stops it at the optimum height for the cups or glasses being used.

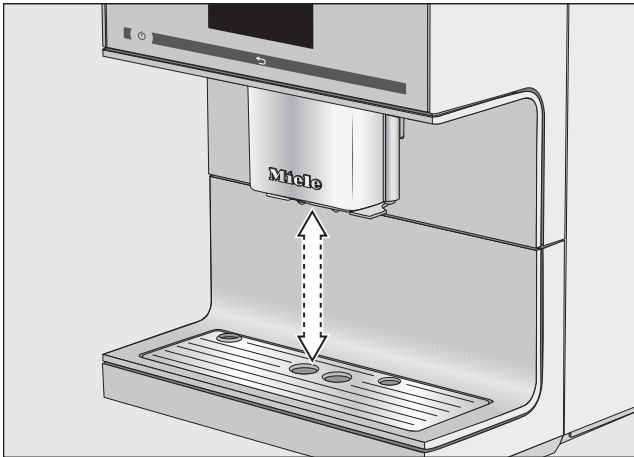

You can switch off spout adjustment. The central spout will then remain in the upper position while drinks are being made. When a maintenance programme is being carried out, the central spout will move to the height of the cleaning containers or into a maintenance position.

Tip: To move the central spout into the maintenance position, touch ↵ for three seconds.

If the coffee machine is switched off, the central spout components can be removed and cleaned at any time. The central spout will be in the middle position when switched off.

Switching the spout adjustment on and off

Start in the Drinks menu.

- Touch ↶.
- Touch Settings .
- Select Spout adjustment.
- Select the required option to switch spout adjustment on or off.
- Touch OK.

The setting is now saved.

Cups should always be pre-heated to allow the flavour of the coffee to develop and be retained. The smaller the volume of the coffee/espresso and the thicker the cup, the more important it is to pre-heat the cup.

You can pre-heat cups or glasses on the cup heating surface on the top of the coffee machine.

The cup heating surface will be heated continually until the coffee machine is switched off.

To switch cup heating on or off

Start in the *Drinks* menu.

- Touch ↶.
- Select *Settings* and then *Cup heating*.
- Select the required setting to switch cup heating on or off.
- Touch *OK*.

The setting is now saved.

The coffee machine is delivered with cup heating switched off.

Pre-heating cups

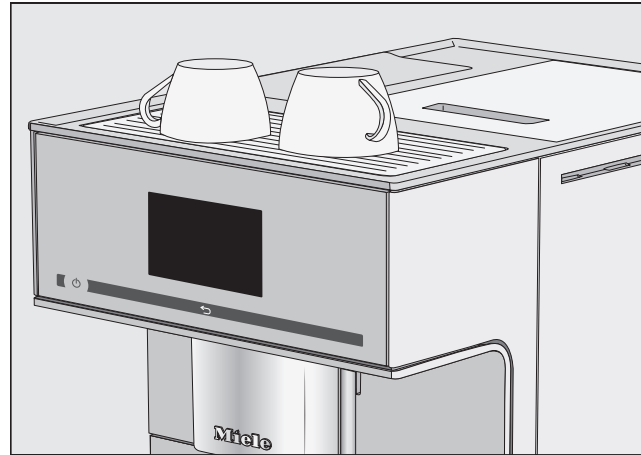

- Arrange the cups or glasses on the cup heating surface on the top of the coffee machine.

Making coffee

The following drinks with milk can be made:

- **Ristretto** is a strong, concentrated espresso. It is prepared with the same amount of coffee as for an espresso but with a lot less water.
- **Espresso** ☞. This is a strong, aromatic coffee with a thick hazelnut brown coloured layer of froth - known as the crema - on top.
When making espresso, use espresso roast coffee beans.
- **Coffee** ☞. This differs from espresso by the increased amount of water and the roast of the beans.
Use coffee beans of the correct roast to make coffee.
- **Long coffee** is a coffee with considerably more water.
- **Long black**. This is made with hot water and two shots of espresso.
- **Caffè Americano** consists of espresso and hot water. The espresso is made first, then the hot water is dispensed into the cup.

 Danger of burning and scalding on the dispensing spouts.

The liquids and steam dispensed are very hot and can cause scalding. Keep well away from the area underneath the spouts when hot liquids and steam are being dispensed.

Do not touch hot components.

Making a coffee

Further drinks can be displayed and selected using the > arrow sensor.

Start in the Drinks menu.



- Place a cup under the central spout.
- Touch the symbol or name of the coffee you want to make.

Dispensing will start.

Cancelling preparation

- Touch Stop or Cancel.

DoubleShot

Select the DoubleShot function if you would like a particularly strong and aromatic coffee. In this case, more coffee beans will be ground and brewed halfway through brewing.

DoubleShot will appear while drinks are being made. This function is available for all drinks except “Ristretto” and “Long black”.

Making a DoubleShot of coffee

Start in the Drinks menu.

- Place a cup under the central spout.
- Select the type of coffee you want.

Dispensing will start and the following will appear underneath:



- Touch DoubleShot.

Double the quantity of coffee beans will be ground and brewed.

Making two portions ☞

With “Two portions” ☞ you can dispense two portions of a drink at the same time.



- Place a cup under each of the coffee dispensers in the central spout.
- Touch ☞.
- Select a drink.

Two portions of the drink will be dispensed.

Coffee pot: making several cups of coffee one after the other

You can make several cups of coffee one after the other automatically with the Coffee pot function (max. 1 litre), e.g. to fill a coffee pot. Up to eight cups can be made in this way.

Start in the Drinks menu.

You can use the Coffee pot function twice in a row. After this, the coffee machine needs a cooling down time of one hour in order to avoid it being damaged.

- Place a sufficiently large container under the central spout.

Making coffee

- Select Coffee pot.
- Select the number of cups you want (3 to 8).
- Follow the instructions in the display.

Each portion of coffee will be brewed and dispensed individually. You can follow the process in the display.

Cancelling Coffee pot

You can interrupt preparation at any time.

- Touch Cancel.

Making coffee drinks with ground coffee

You can make coffee using ready ground coffee. This allows you to make a decaffeinated coffee if the bean container is already filled with regular coffee beans, for example.

To do this, fill the ground coffee drawer with ground coffee. The coffee machine will use all the ground coffee which has been added to the chute to make the next coffee.

Only **one** portion of coffee or espresso can be made at a time.

Adding ground coffee

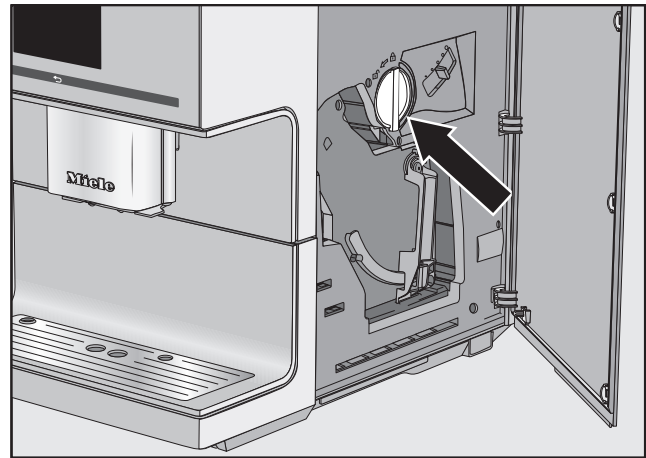

The coffee scoop is integrated into the ground coffee drawer.

- Open the appliance door.
- Turn the handle (see arrow) to the left to remove the ground coffee drawer.

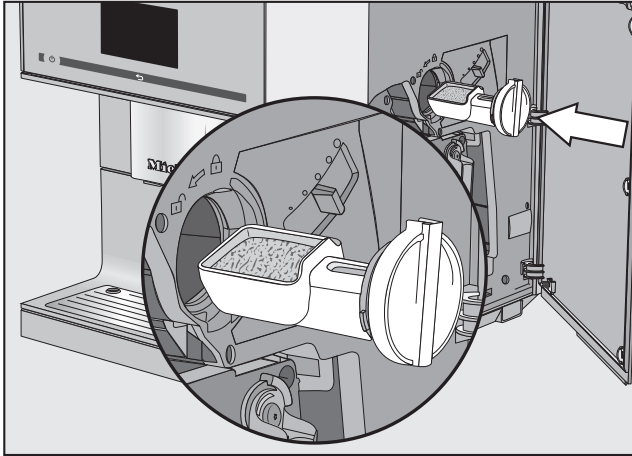

- Fill the coffee scoop with ready ground coffee. Push the ground coffee drawer horizontally into the ground coffee chute.

In order to not overfill the brew unit, place a maximum of **2** level scoops of coffee in the ground coffee chute.

- Turn the handle clockwise to fill the brew unit with the ground coffee and to close the ground coffee chute.
- Close the appliance door.

Use ground coffee? will appear in the display.

Making coffee with ground coffee

- Touch Yes.

You can now select which type of drink you would like to make with ground coffee.

- Place a cup under the central spout.
- Select a drink.

The coffee will now be made.

If you select No, the ground coffee will be disposed of in the waste container without being brewed. The appliance rinses.

Making coffee with milk

The following drinks with milk can be made:

- **Cappuccino** ☕ consisting of approx. 2/3 milk froth and 1/3 espresso.
- **Latte macchiato** ☕ consisting of 1/3 each of hot milk, milk froth and espresso.
- **Caffè latte** consists of coffee and hot milk.
- **Cappuccino italiano** has the same proportions of milk froth and espresso as a cappuccino. The difference is that the espresso is added first and then the milk froth.
- **Espresso macchiato**. This is an espresso with a small amount of milk froth on top.
Select a cup which can hold at least 100 ml for this drink.
- **Flat white** is a large cappuccino: lots of espresso with plenty of milk froth.
- **Café au lait**. This is an espresso with slightly hotter milk.

Hot milk or **milk froth** can also be made.

Tip: Using cold cow's milk (< 10 °C) with a protein content of at least 3% will produce the perfect milk froth. You can select milk with a fat content according to preference. With whole milk (at least 3.5% fat), the milk froth will be slightly creamier than with low-fat milk.

 Danger of burning and scalding on the dispensing spouts.

The liquids and steam dispensed are very hot and can cause scalding.

Keep well away from the area underneath the spouts when hot liquids and steam are being dispensed.

Do not touch hot components.

Most additives contain sugar which will adhere to the milk pipework and damage the machine.

The milk used must not contain any additives.

As soon as you select a drink containing milk the machine will start to heat up. The milk will be drawn up into the central spout where it is heated by steam and also frothed for drinks requiring milk froth.

If you have not made any milk drinks for a while, rinse the milk system thoroughly before making the first drink.

Making coffee with milk

Using the milk flask

The stainless steel flask keeps milk cool for longer. Good milk froth can only be made with cold milk ($< 10\text{ }^{\circ}\text{C}$).

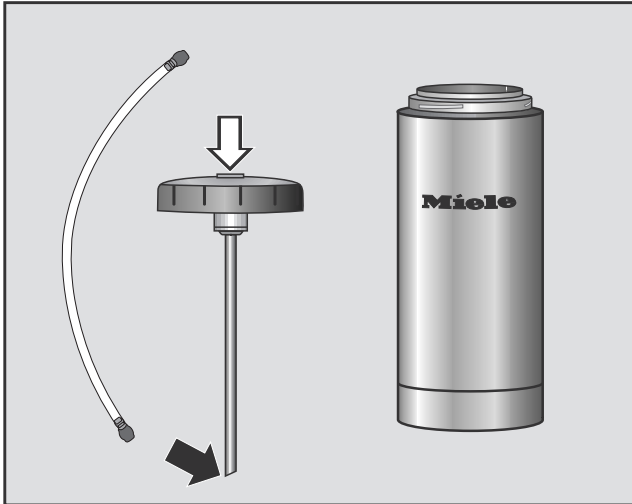

- Connect the stainless steel suction tube to the inside of the lid. Make sure that the slanted end of the stainless steel tube is pointing downwards.
- Fill the milk flask with milk up to a maximum of 2 cm below the rim. Seal the milk flask with the lid.
- Connect the milk tube to the top of the lid. Make sure that the connecting piece clicks into position.



- Place the milk flask next to the coffee machine. Connect the milk tube to the aperture in the central spout.

If the central spout is in the uppermost position, it will be difficult to connect the milk pipework.

To bring the central spout into the maintenance position:

- Touch \leftarrow for three seconds.
- Touch *OK* to leave the maintenance position.

Making coffee with milk

Using milk cartons or bottles

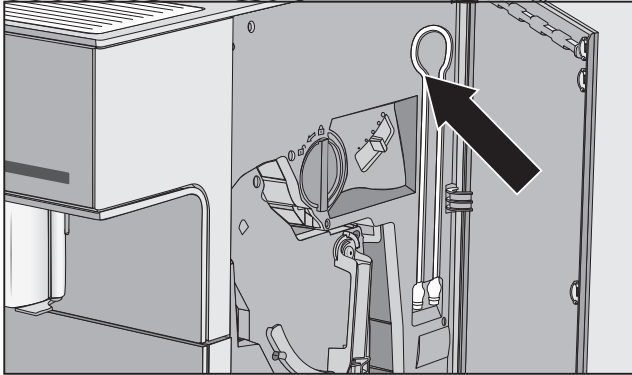

The milk tube for cartons and other suitable containers is located behind the appliance door.

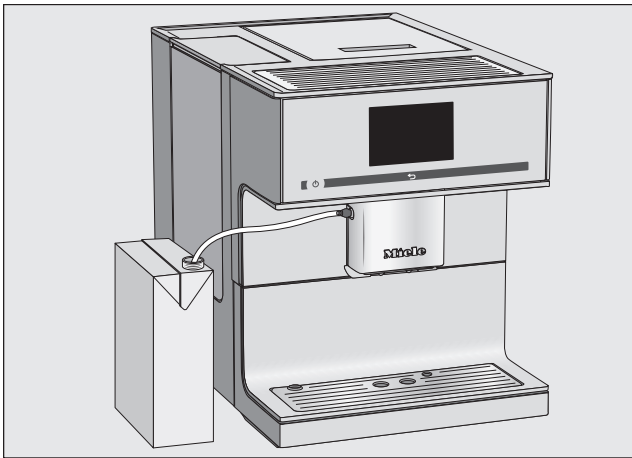

- Connect the milk tube to the aperture in the central spout.
- Place a container with sufficient milk in it beside the coffee machine.
- Place the end of the milk tube in the container. Make sure that it is sufficiently immersed in the milk.

Making drinks with milk

The milk pipework must be connected to the central spout and submerged in sufficient cold milk.

Start in the *Drinks* menu.

- Place a suitable container underneath the central spout.

- Select a drink.

Dispensing will start.

Cancelling a drink

You can finish dispensing individual drink components early, e.g. if the cup is not big enough.

Cancelling individual drink components

- Touch *Stop*.

Cancelling the entire drink preparation

- Touch *Cancel*.

 Danger of burning and scalding on the hot water spout!

The liquids and steam dispensed are very hot and can cause scalding.

Keep well away from the area underneath the hot water spout when hot liquids and steam are being dispensed.

Do not touch hot components.

This machine is not intended for commercial or scientific purposes. Temperatures given are approximate and can vary according to ambient conditions.

To make tea you can select from the following options:

- **Green tea** approx. 80 °C
- **Herbal tea** approx. 90 °C
- **Fruit tea** approx. 90 °C
- **Black tea** approx. 90 °C

The type of tea determines the preset temperature.

The respective dispensing temperatures are recommended by Miele for making black tea, green tea, herbal or fruit tea.

Follow the instructions for making tea on the tea packaging.

The taste of the tea will be affected by the type of water used. Water should be as soft as possible to allow the aroma to develop.

Whether you use loose tea leaves, blended tea or tea bags depends on your own personal preference.

The amount of tea and the brewing time will vary depending on the type of tea. Always follow the recommendations of the manufacturer on the packaging or of the retailer. The amount of hot water used can be adjusted depending on the type of tea and the size of the cup (see “Portion size”)

Tip: Store the tea in a cool, dark place in tightly sealed containers. It is best to buy smaller amounts to prevent loss of aroma.

TeaTimer

You can use the TeaTimer to start a minute minder when making tea. A brewing time of 2 minutes is preset as standard. You can adjust the preset brewing time according to your preferences (between 1:00 and 23:59 minutes).

The TeaTimer can be started twice consecutively.

If you have started a TeaTimer, while the brewing time is counting down you can continue to use the coffee machine as normal. An audible tone will sound after the brewing time has elapsed.

If you have switched off audible tones, you will not be reminded when the brewing time has finished.

Switching the TeaTimer on and off

Start in the Settings  menu.

■ Select Timer and then TeaTimer.

- On: the TeaTimer is displayed while the hot water is being prepared. The TeaTimer can be started after preparation.

Tea

– Off: the TeaTimer is not displayed.

- Select the setting you want and confirm with *OK*.

Making tea

The hot water spout is located to the right of the central spout.

Use the arrow sensor > to display and select the types of tea. Different types of tea can be found in the drinks menu after Milk froth.

Start in the Drinks menu.

- Pour loose tea into a tea filter or similar or take a tea bag from the packet.
- Place the tea filter or the tea bag in the tea cup.



- Place the cup under the hot water spout.
- Select the type of tea from the display.

Hot water will be dispensed into the cup.

You can now start the minute minder for brewing time if the TeaTimer is switched on.

Starting the TeaTimer

TeaTimer appears in the bottom left of the display.



- Touch TeaTimer.

TeaTimer will be selected. After dispensing, the editor will open with a suggested time.

- Adjust the brewing time if necessary and touch *OK*.

An audible tone will sound after the brewing time has elapsed.

- Now remove the tea leaves or the tea bag.

Cancelling tea preparation

- Touch Stop or Cancel.

Tea pot: making several cups of tea, one after the other

You can make several cups of tea one after the other automatically with the Tea pot function (max. 1 litre), e.g. to fill a tea pot. Up to eight cups can be made in this way.

Start in the Drinks menu.

- Place the tea or tea bag in the tea pot.
- Place a suitably sized tea pot under the hot water spout.
- Select Tea pot.
- Select the type of tea you want.
- Select the number of cups you want (3 to 8).
- Follow the instructions in the display.

The teapot will be filled. You can follow the process in the display.

You can interrupt preparation at any time:

- Touch Cancel.

Dispensing hot water

 Danger of burning and scalding on the hot water spout!

The liquids and steam dispensed are very hot and can cause scalding.

Keep well away from the area underneath the spouts when hot liquids and steam are being dispensed.

Do not touch hot components.

The hot water has a temperature of approx. 90 °C when dispensed.

The amount of hot water used can be adjusted depending on the size of the cup (see “Portion size”).

Start in the Drinks menu.

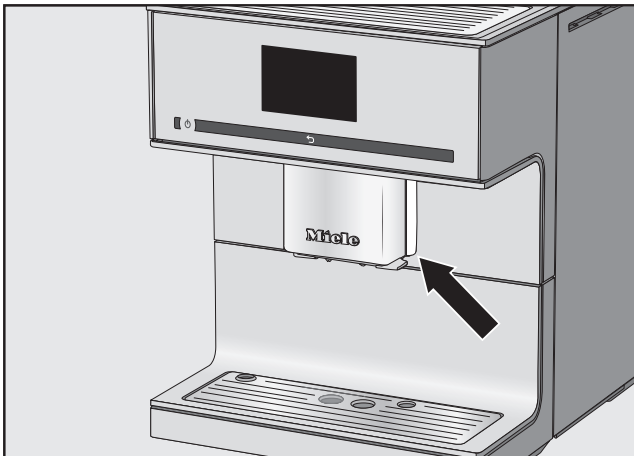

- Place a suitable container underneath the hot water spout.

- Select Hot water.

Dispensing will start.

Cancelling a drink

- Touch Stop or Cancel.

You can individually adjust the following parameters for each drink:

- Ground quantity
- Brewing temperature
- Pre-brewing

Changing drink parameters

Start in the Drinks menu.

- Select Process.
- Touch Change drink.
- Select a drink.

Now you can adjust the portion size (see “Portion size”) or set the drink parameters.

- Touch Drink parameters.
- Select Amount of coffee, Brew temperature or Pre-brewing.
- Select the setting you want and touch *OK*.

The overview of drink parameters will appear in the display.

- Touch *OK* again to save your changed settings.

Ground quantity

The coffee machine can grind and brew 6–14 g of coffee beans per cup. The greater the quantity, the stronger the coffee.

There are various ways to tell whether the amount of coffee is set correctly:

The amount of coffee is **too low** if

- espresso or coffee flows into the cup too quickly,
- the crema is very pale and uneven,

- the espresso or coffee lacks body.

Increase the amount of coffee so that more ground coffee is brewed.

The amount of coffee is **too high**, if

- espresso or coffee flows into the cup very slowly,
- the crema is dark brown,
- the espresso or coffee tastes bitter.

Decrease the amount of coffee so that less ground coffee is brewed.

Brewing temperature

The ideal brewing temperature will depend on

- the type of coffee being used,
- whether an espresso or a coffee is being made, and
- the air pressure in the region.

Tip: Not all types of coffee tolerate high temperatures. Several types are sensitive to high temperatures, resulting in an impaired crema and taste.

Pre-brewing the coffee

When the pre-brewing function is switched on, the freshly ground coffee is first moistened with a little hot water. Then the remaining water is forced through the moistened coffee at high pressure. This helps release the flavour of the coffee.

You can set pre-brewing for a short or long length of time, or deselect “Pre-brewing” altogether.

The machine is supplied with the “Pre-brewing” function switched off.

Parameters

Grinder setting

When the beans are ground correctly, the coffee or espresso will flow evenly into the cup with a good crema. The crema should have an even hazelnut brown colour.

The grinder setting you select will be used for all coffee drinks.

There are various ways to tell whether the coffee grinder is set correctly.

The coffee has been **too coarsely** ground if:

- Espresso or coffee flows into the cup too quickly,
- the crema is very pale and uneven,

Set a finer grinder setting.

The coffee has been **too finely** ground if:

- espresso or coffee flows into the cup very slowly,
- the crema is dark brown,

Set a coarser grinder setting.

Only adjust the grinder one setting at a time.

Start making a new drink, to grind beans again. Adjust the grinder setting one setting at a time again.

- Open the machine.

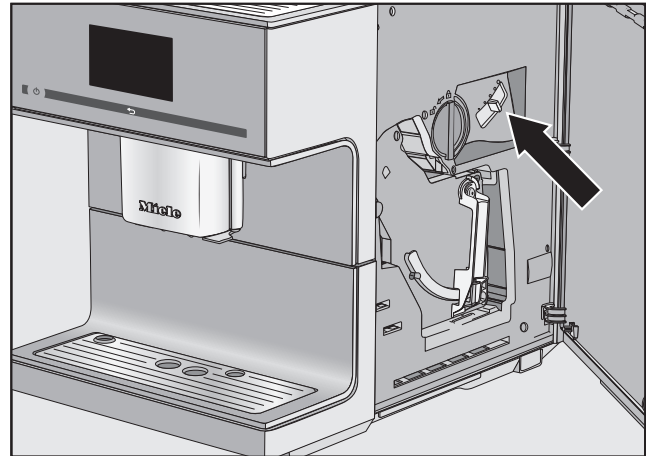

- Push the slide control a maximum of one setting to the left (for finer grinding) or one setting to the right (for coarser grinding).
- Close the machine.
- Make one cup of coffee.

Adjust the grinder setting again.

The altered grinder setting will not be used until after the second coffee has been dispensed.

The flavour of the coffee produced depends not only on the type of coffee, but also on the amount of water used. You can programme the amount of water for all coffee drinks, tea and hot water to suit the size of your cups and to suit the type of coffee you are using. This does not alter the amount of coffee used.

For coffee drinks with milk you can also set the amount of milk or milk froth to suit your personal taste. You can also set the portion sizes for hot milk and milk froth.

The changed portion size is always saved in the current profile. The name of the current profile is shown in the top left of the display.

If the water container becomes empty whilst making a drink, the machine will stop programming the portion size. The portion size will **not** be saved.

Start in the Drinks menu.

- Place the cup you want under the central spout or hot water spout.
- Select Process.
- Touch Change drink.
- Select the drink and then touch Portion size.

If you have selected a drink with milk or tea, portion programming will start immediately. Portion size does not need to be opened separately.

The drink will be made and Save will appear in the display, as soon as the minimum dispensing amount is reached.

- When the cup is filled to the level you want, touch Save.

If the maximum amount is reached, preparation stops and the maximum possible amount is saved.

If you want to change the portion size for coffee drinks made with milk or hot water, the ingredients which make up the drink will be saved one after the other while the drink is being made.

The programmed mix of ingredients and portion sizes will now be dispensed every time that particular drink is selected.

Resetting drinks

You can reset portion sizes and parameters individually or for all drinks back to their factory default setting.

Start in the Drinks menu.

- Select Process.

Resetting a drink

- Touch Reset drink.

- Select a drink.

Reset drink to default settings? will appear in the display.

- Touch Yes to confirm.

Resetting all drinks

- Touch Reset all drinks.

Reset all drinks to default settings? will appear in the display.

- Touch Yes to confirm.

In addition to the Miele drinks menu (Miele profile), you can enter up to 10 individual profiles to cater for different tastes and preferences.

The portion quantities and parameters for coffee and milk drinks, hot water and tea can be adjusted in each profile.

The name of the current profile is shown in the top left of the display.

Creating a profile

- Touch Profiles.
- Touch Create profile.

The editor will open in the display.

- Enter the name you want (max. 8 characters) and then touch Save.

The profile is created. You can now create drinks (see “Profiles: creating and processing drinks”).

Opening the Profiles menu and selecting a profile

Start in the Drinks menu.

- Touch Profiles.
- Select the profile you want.

You can now make drinks from the profile, change the parameters for individual drinks or process profiles.

Processing profiles

When you have created at least one profile you can choose from the following options under Process:

- **Change name** if you want to alter the name of a profile.

- **Delete profile** if you want to delete a profile.
- **Change profile** to set whether the coffee machine automatically always reverts to the Miele drinks menu or retains the last selected profile.

- Select Process.

Change name

- Touch Change name.
- Select the profile you want.
- Change the name as you wish and then touch Save.

The changed profile name is saved.

Deleting a profile

- Touch Delete profile.
- Touch the profile you want and then touch *OK*

The profile will be deleted.

Change profile

You can programme the coffee machine so that it changes back to the Miele standard profile automatically after each drink is dispensed or so that it retains the most recently selected profile.

- Touch Change profile.

You now have the following options:

- **Manually:** the selected profile will remain active until you select another profile.
- **After each use:** The machine will change back to the Miele drinks menu automatically after a drink is dispensed.

Profiles

- **When switched on:** Each time the machine is switched on it will automatically select the Miele drinks menu regardless of which profile was set before the machine was last switched off.
- Select the required option and touch *OK*.

Profiles: creating and processing drinks

You can save frequently made drinks in a profile with your own individual settings (see “Profiles”).

You can also change the names of your drinks and delete any unwanted drinks from your profile. You can save a maximum of 10 drinks in a profile.

Start in the Drinks menu. First open the profile you want:

- Touch Profiles.
- Select the profile you want.

The name of the current profile is shown in the top left of the display.

Creating a drink

You can create new drinks based on existing drinks.

- Touch Create drink.
- Now select a drink.
- Change the portion size or drink parameters for this drink.

Preparation will begin and you can save the portions of each component as desired.

- Enter a name for the new drink (maximum 8 characters) and touch Save.

The newly created drink will appear in the profile.

Changing a drink: changing the portion size(s), drinks parameters and names

The desired profile with the newly created drinks will appear in the display.

- Select Process drink.

- Touch Change drink.
- Select a drink.

You can now either change the portion size(s), drinks parameters or the names as described.

Delete drink

The desired profile with drinks will appear in the display.

- Select Process drink.
- Touch Delete drink.
- Select the drink and touch OK.

The entry will be deleted.

Profiles: making drinks

Start in the Drinks menu.

- Touch Profiles.
- Select the profile you want.

The name of the profile selected will be shown in the top left of the display. Now you can make the drink you want.

- Place a suitable container underneath the central spout.
- Select a drink.

Dispensing will start.

In Expert mode you can change the amount of coffee and portion size while the drink is being made. The setting will **not** be saved and will only apply for the current drink.

Switching Expert mode on and off

Start in the Drinks menu.

- Touch ↶.
- Select Settings  and then Expert mode.
- To switch Expert mode either on or off, select the option you want.
- Touch *OK*.

If Expert mode was switched on you can now change the amount of coffee and/or the portion size while the drink is being dispensed.

Expert mode: changing the amount of coffee and portion size

Start in the Drinks menu.

The parameters can only be changed when the respective ingredient is being processed while the drink is being made.

Changing the amount of coffee

- Select a coffee drink.

Dispensing will start. You can now change the amount of coffee while the beans are being ground.

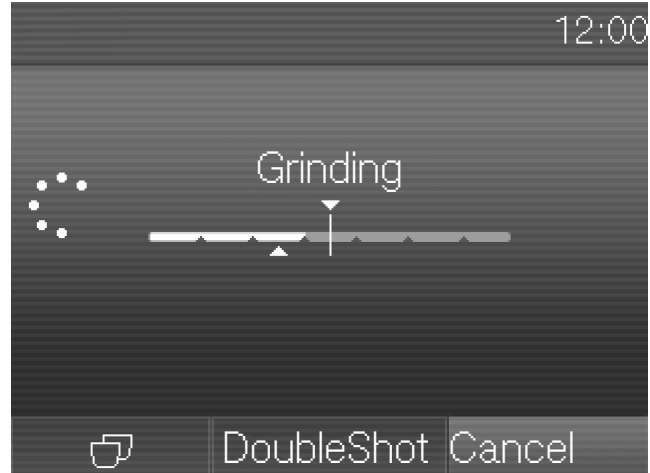

- Touch the segments and adjust the indicator (small triangle) as you wish.

When you touch the segments *Adjust* will appear. When you touch the segments will appear.

Changing portion size

- Select a drink.

If you select *DoubleShot* or two portions , Expert mode cannot be used to change the portion size.

Dispensing will start. You can adjust the portion size while it is being dispensed, e.g. individually change the amount of hot milk, milk froth and espresso for Latte macchiato.

- Touch the segments and adjust the indicator (small triangle) as you wish.

Settings

You can use the “Settings” menu to customise the coffee machine to suit your requirements.

Some settings which can be found in the Settings menu are described in their separate sections in the operating instructions.

Opening the Settings menu

Start in the Drinks menu.

- Touch ↶.
- Select Settings ▢.

You can now check or make alterations to settings.

The settings which are currently selected will be marked in colour.

Touching ↶ takes you back to the previous menu.

Changing and saving settings

Start in the Settings ▢ menu.

- Select the option you want to change.
- Select the setting you want and confirm with *OK*.

The setting is now saved.

Possible setting options

The factory default for each option has a * next to it.

Option	Available settings
Language 	deutsch, English and other languages Country
Time	Show – On / Off* / Night dimming Clock format – 24 h* / 12 h (am/pm) Set
Date	
Timer	Timer 1 – Set : Switch on at / Switch off after (00:20)* / Switch off at – Days of the week: Monday / Tuesday / Wednesday / Thursday / Friday / Saturday / Sunday – Activate : Switch on at (Yes / No*) / Switch off at (Yes / No*) Timer 2 – Set : Switch on at / Switch off at – Days of the week: Monday / Tuesday / Wednesday / Thursday / Friday / Saturday / Sunday – Activate : Switch on at (Yes / No*) / Switch off at (Yes / No*) – TeaTimer (On / Off*) – Descaling timer
Expert mode	On / Off*
Eco mode	On* / Off

Settings

Option	Available settings
Lighting	Machine switched on – Set the brightness Machine switched off – Brightness / Switch off after
Info	Number of drinks – Total no. of drinks / Total no. of coffee drinks / Total no. of tea drinks: / Espresso / ... No. of drinks until – Descaling / Degrease the brew unit
System lock	On / Off*
Water hardness	Soft Medium Hard* Very hard
Brightness	Set the brightness
Volume	Audible tone Keypad tone
Cup heating	On / Off*
Spout adjustment	On* / Off

Option	Available settings
Miele@home	Set up If Miele@home is set up: <ul style="list-style-type: none">- Deactivate (Activate)- Set up again- Connection status
If Miele@home is set up: Remote control	On* / Off
If Miele@home is set up: RemoteUpdate	On* / Off
Service	Evaporate (Yes / No) Demo mode (On / Off*)
Factory default	Appliance settings <ul style="list-style-type: none">- Reset / Do not reset Network configuration <ul style="list-style-type: none">- Reset / Do not reset

Settings

Language

You can select the language (and country variant of that language) for all display text.

Tip: If you select the wrong language by mistake, you can find the “Language” option by following the flag symbol .

Time

You can set the time display, the clock format and the time.

Display (Clock display)

You can choose one of the following options:

- On: the time and date are always visible in the display when the machine is switched off.
- Off: the time and date are not visible in the display when the machine is switched off.
- Night dimming: the time and the date are displayed from 5:00 to 23:00.

Depending on which option you select, the machine may use more energy. A message appears in the display to inform you of this.

Clock format

The options are:

- 24 hour display (24 h)
- 12 hour display (12 h (am/pm))

Setting

Set the hours and the minutes.

If you have connected the coffee machine to a WiFi network and have signed in to the Miele@mobile app, the time will be synchronised based on the country setting in the Miele@mobile app.

Timer

There are two timers with the following functions:

The coffee machine

- switches on at a particular time, e.g. in the morning for breakfast (Switch on at).
- switches off at a particular time (Switch off at),
- switches off after a particular length of time if none of the sensors has been touched or a drink has not been made (Switch off after; available with Timer 1 only).

You can allocate the timer functions to individual days of the week.

For Switch on at and Switch off at, the timer must be activated and at least one day of the week allocated.

Selecting a timer

The options are:

- **Timer 1:** Switch on at, Switch off at, Switch off after
- **Timer 2:** Switch on at, Switch off at

Switch on at

The coffee machine will **not** switch on at the required time if you have activated the system lock. The timer settings are deactivated.

If the coffee machine has switched itself on automatically **three times** via the Switch on at timer function and no drinks have been dispensed, the machine will not switch itself on again automatically. This prevents the coffee machine from switching itself on unnecessarily, for example, whilst you are away on holiday.

The programmed times will, however, remain in memory and will be reactivated after manually switching the machine on again.

Switch off at

In the event of a longer absence the programmed times will remain in memory and will be reactivated after manually switching the machine on again (see “Switch on at”).

Switch off after

The Switch off after timer function is only available in Timer 1.

If none of the sensors have been touched or no drink has been made, the coffee machine will switch itself off after 30 minutes to save energy.

You can change this to another time of between 15 minutes and 9 hours.

Allocating days of the week

The selected day of the week will be marked by .

- Select the required day of the week.
- When all required days of the week are marked, touch *OK*.

Activating and deactivating the timer

If you have selected *On* or *Night dimming* for the time display:

when *Switch on at* is activated for the timer, the ⌚ symbol and the desired switching on time will appear in the display 23:59 hours before.

If the system lock is activated, the *Switch on at* option for the timer cannot be selected.

Select the timer function you want to use. The selected timer function will have a next to it.

Eco mode

The Eco mode is an energy-saving mode.

If Eco mode is switched on, the coffee machine will heat up anew every time a drink is made, so that making a drink takes longer.

If Eco mode is switched off, the coffee machine uses considerably more energy. The coffee machine heats up for dispensing the first drink after switching on. After that the machine remains heated up and drinks can be dispensed without having to wait so long.

A message regarding the altered energy consumption will appear in the display.

Settings

Lighting

You have the following options:

- The machine is switched on: set the brightness.
- The machine is switched off: set the brightness and set the time the lighting should switch off.

When the coffee machine is switched on, it remains lit up for a certain length of time after the last action. This time cannot be adjusted.

Water hardness

If a descaling cartridge is **not** fitted and you descale the coffee machine using descaling tablets, the machine should be set to the local water hardness. A prompt to descale the machine will then appear in the display at the correct time.

Programme the coffee machine to the water hardness level of your area so that it functions correctly and does not get damaged.

Contact your local water supplier to find out your local water hardness range if necessary.

If you are using bottled drinking water, e.g. mineral water, select settings according to the calcium content. The calcium content is given on the label of the bottle in mg/l Ca²⁺ or ppm (mg Ca²⁺/l).

Do not use carbonated water.

Tip: If your water hardness is >21 °dH (3.7 mmol/l), we recommend instead to use bottled drinking water (< 150 mg/l Ca²⁺). This will mean your coffee machine will need to be descaled less often and there will be less impact on the environment because less descaling agent will be used.

The machine is programmed ex-works to hardness level 3.

The machine has four programmable levels:

°dH	mmol/l	ppm (mg/l CaCO ₃)	Setting*
0 – 8.4	0 – 1.5	0 – 150	Soft 1
8.4 – 14	1.5 – 2.5	150 – 250	Medium 2
14 – 21	2.5 – 3.7	250 – 375	Hard 3
> 21	> 3.7	> 375	Very hard 4

* The hardness level shown in the display may differ from the hardness level in your area. You **must** follow the values in the chart to set your machine to your local hardness level.

Info (display information)

The Info option allows you to see the number of portions made for each drink.

You can also see how many portions can be dispensed before the brew unit needs to be degreased (No. of drinks until).

To return to the previous display, touch ↩.

Locking the coffee machine (System lock)

You can lock the coffee machine to prevent it being used without your knowledge, by children, for example.

Activating and deactivating the system lock

When the system lock is activated, the timer settings for Switch on at are deactivated. The coffee system will **not** switch on at the time set.

Overriding the system lock

If you touch the On/Off  sensor,  will appear.

- Touch  as long as a relevant instruction appears in the display.

As soon as you switch the coffee machine off, the system lock will be activated again and the coffee machine is locked.

Miele@home

The following points may appear under Miele@home:

- Set up: This option only appears if the coffee machine has not previously been connected to a WiFi network or the Network configuration has been reset.
- Deactivate*/Activate*: The settings for the WiFi network are retained, but the network is switched on or off.
- Connection status*: Information about the WiFi connection is displayed. The symbols indicate the strength of the connection.

- Set up again*: The settings for the current WiFi network will be reset. The WiFi connection will be set up again.

* appears when the coffee machine is connected to a WiFi network.

Display brightness

You can set the display brightness using the bar chart.

Volume

You can set the volume of the buzzer and keypad tones using the bar chart.

Service

Evaporate

The coffee machine should be evaporated before it is stored for a long period of time or transported any distance (see “Transporting the machine”)

Demo mode

Do not activate this setting for domestic use!

The coffee machine can be demonstrated in the showroom using Demo mode. In this mode the machine lights up but drinks cannot be made or actions taken.

Settings

Factory default

You can reset the coffee machine to its factory default settings.

Please refer to the “Overview of available settings” chart for the factory settings.

Network configuration

The settings for the WiFi network will be reset.

Your coffee machine is WiFi enabled and can be operated via the Miele@mobile app using a mobile device, e.g. smartphone or tablet.

Please ensure you adhere to the warning and safety instructions in these operating instructions even when you are operating the coffee machine via the Miele@mobile app.

Energy consumption increases when the coffee machine is connected to a WiFi network. This applies even when the coffee machine is switched off.

Setting up the network (Miele@home)

Networking is deactivated ex-works.

To connect the coffee machine to a WiFi network, the Miele@mobile app must be installed on a mobile device (e.g. smartphone). You sign in to the app with a user account.

The Miele@mobile app can be downloaded free of charge from the relevant app store. Please ensure you have the required version of your operating system.



- Make sure that the signal of your WiFi network is sufficiently strong in the place where you want to set up your coffee machine.

Start in the Settings  menu.

- Select Miele@home and then Set up.

You can now select the connection method.

- via App
- via WPS

Networking the coffee machine via the Miele@mobile app

Additionally you will require the following to sign in:

- Your WiFi network password
- The password of your coffee machine

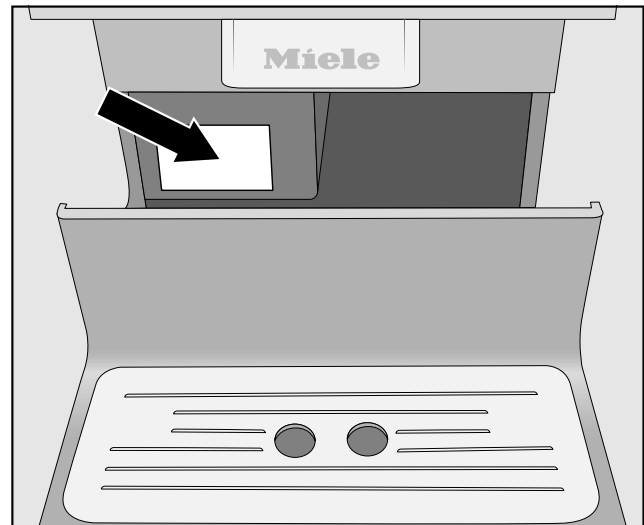

The password of your coffee machine is the serial number located on the data plate.

Note that the first digit you enter must not be “0”. Start with the following digit. If your serial number is, for example, “023423585” your password will be “23423585”.

- Select the connection method Via App.
- Start the Miele@mobile app and following the instructions in the app.

Networking

Connection successfully established appears when the coffee machine is connected to a WiFi network.

- Confirm with *OK*.

Networking the coffee machine via WPS

To use the *Via WPS* connection method, your router must have the WPS function.

- Select the connection method *Via WPS*.
- Follow the instructions in the display.

Connection successfully established appears when the coffee machine is connected to a WiFi network.

- Confirm with *OK*.

To use the *Miele@home* functions, you need to sign on your coffee machine in the app as well.

- Follow the prompts in the app.

Setting up the network again

If your WiFi network has changed, you can set up *Miele@home* for your coffee machine again.

Start in the *Settings*  menu.

- Select *Miele@home* and then *Set up again*.
- Follow the instructions in “*Setting up the network*”.

Remote control



Remote control is only visible when the coffee machine is connected to a WiFi network.

You can change the coffee machine settings, for example, when remote control is switched on in the *Miele@mobile* app. To start making a drink via the app, *MobileStart* must be additionally activated.

Remote control is activated ex-works.

Switching remote control on or off

Start in the *Drinks* menu.

- Touch .
- Select *Settings*  and then *Remote control*.
- Select the required option to switch remote control on or off.

MobileStart

With MobileStart you can start making a drink, for example, via the Miele@mobile app.

 Danger of burning and scalding on the dispensing spouts.

If liquids or steam are dispensed while the machine is unsupervised, persons may burn themselves if they place body parts under the central spout or touch hot components.

Ensure that no one, especially children, can be harmed if the machine is operated without supervision.

Automatic descaling will not start if MobileStart is activated. The pipework is not pre-warmed when the machine is switched on either so that the cup under the central spout is not filled with rinse water.

Milk is not cooled in the milk flask. If you want to start making a drink with milk using the app, make sure that the milk is sufficiently cold ($< 10\text{ }^{\circ}\text{C}$).

If the coffee machine is being operated manually, it cannot be operated via the app. Operation on the appliance takes precedence.

To start making drinks remotely, MobileStart must be activated and the coffee machine must be ready to use. This means:

- The water container is sufficiently filled.
- The bean container contains enough beans.

- The drip tray and waste container are empty.
- If milk was used before the machine was last switched off, the milk pipework needs to be rinsed before switching off.
- If milk is being prepared, the milk flask must be attached. Pay attention to the temperature of the milk.
- A sufficiently large, empty cup is placed under the central spout.

MobileStart will be deactivated after 24 hours.

If you are making a drink with MobileStart, you will be notified of drink dispensing with acoustic and optical signals. These signals cannot be changed or switched off.

Switching MobileStart on and off

If you want to use MobileStart, the Remote control option must be switched on.

Start in the Drinks menu.

- Touch .
- Select MobileStart.
- Select the required option to switch remote control on or off.

You can now starting making a drink via the app. Follow the prompts for doing this.

Networking

RemoteUpdate

The RemoteUpdate function is used for updating the software in your coffee machine.

RemoteUpdate is activated ex-works.

If you do not install a RemoteUpdate, you can continue to use your coffee machine in the usual way. However, Miele recommends installing RemoteUpdates.

Activation

The RemoteUpdate menu option is only displayed and can only be selected if you have added your coffee machine to your WiFi network.

Miele's RemoteUpdate function can only be used if the coffee machine is connected to a WiFi network and you have an account in the Miele@mobile app. The coffee machine must be registered in the app.

See the Miele@mobile app for terms and conditions of use.

Some software updates can only be carried out by Miele Service.

Running a RemoteUpdate

If a RemoteUpdate is available for your coffee machine, it will be displayed automatically for you.

You can choose to start the RemoteUpdate immediately or wait until later. If you select "Start later", the query will appear again the next time the coffee machine is switched on.

The RemoteUpdate can take a few minutes.

Please note the following information about the RemoteUpdate function:

- You will only receive a message when a RemoteUpdate is available.
- Once a RemoteUpdate has been installed, it cannot be undone.
- Do not switch off the coffee machine during a RemoteUpdate. Otherwise, the RemoteUpdate will be aborted and will not be installed.

 Risk to health due to inadequate cleaning

Heat and moisture inside the coffee machine can cause coffee residues to become mouldy and/or milk residues to go off and pose a risk to health.

Carefully clean the coffee machine regularly.

Overview of cleaning intervals

Recommended frequency	What do I have to clean/maintain?
Daily (at the end of the day)	Water container
	Waste container
	Drip tray and drip tray cover
	Stainless steel milk flask
	Cup sensor
Once a week (more often if heavily soiled)	Central spout
	Brew unit
	Area underneath the brew unit and the drip tray
	Housing
Once a month	Bean container
	Ground coffee chute and Ground coffee drawer
	Water container filter (or as required)
When prompted	Milk pipework
	Degrease the brew unit (using cleaning tablets)
	If necessary, descale the appliance when prompted in the display

Cleaning and care

Cleaning by hand or in the dishwasher

Please note that the brew unit is **not** dishwasher safe.

Clean the brew unit by hand only under warm running water. **Do not use washing-up liquid or any other cleaning agent.**

The following components must be cleaned **by hand only**:

- Central spout stainless steel cover
- Cup sensor
- Brew unit
- Stainless steel milk flask
- Bean container lid

The maximum temperature of the dishwashing programme selected must not exceed 55 °C.

Contact with natural dyes such as those found in carrots, tomatoes and ketchup may discolour the plastic parts in the dishwasher. This discolouration does not affect the stability of the parts.

The following components are **dishwasher safe**:

- Drip tray and lid
- Drip tray cover
- Water container
- Waste container
- Central spout (without stainless steel cover)
- Lower panel
- Ground coffee drawer

 **Danger of burning and scalding on hot components or by hot liquids.** Components can become very hot during operation. Touching hot components can cause burning. The liquids and steam dispensed are very hot and can cause scalding.

Keep well away from the area underneath the spouts when hot liquids and steam are being dispensed.

Always allow the coffee machine to cool down before cleaning it.

Please be aware that water in the drip tray can also be very hot.

 Risk of damage due to moisture ingress.

The steam from a steam cleaning appliance could reach live electrical components and cause a short circuit.

Do not use a steam cleaner to clean the coffee machine.

It is important to clean the machine regularly, as the used coffee grounds will soon go mouldy. Milk residues can go off and can block the milk pipework.

Unsuitable cleaning agents

Contact with unsuitable cleaning agents can alter or discolour the external surfaces. All surfaces are susceptible to scratching. Scratches on glass can in some circumstances lead to breakage.

Remove all cleaning agent residues immediately. To protect the machine and surrounding surfaces from damage, make sure you remove any spillages or splashes of descaling agent immediately.

To avoid damaging the surfaces, do not use:

- cleaning agents containing soda, ammonia, acids or chlorides
- solvent-based cleaning agents
- cleaning agents containing descaling agents (unsuitable for cleaning the housing)
- stainless steel cleaning agents
- dishwasher cleaners (unsuitable for cleaning the housing)

- glass cleaning agents
- cleaning agents for ceramic hobs
- oven cleaner
- abrasive cleaning agents, e.g. powder cleaners and cream cleaners
- hard, abrasive brushes or sponges, e.g. pot scourers, brushes or sponges which have been previously used with abrasive cleaning agents
- melamine eraser blocks
- sharp metal scrapers
- steel wool or stainless steel wire scourers

Cleaning and care

Clean the drip tray and waste container

 Danger of burning and scalding on hot components or by hot liquids. Components can become very hot during operation. Touching hot components can cause burning. The liquids and steam dispensed are very hot and can cause scalding. If the pipework has just been rinsed, wait a while before removing the drip tray.

Please be aware that water in the drip tray can also be very hot. Do not touch hot components.

Clean the drip tray and waste container **every day** to avoid unpleasant smells and mildew.

The waste container is located in the drip tray. Water from rinsing also collects in the waste container.

A prompt will appear in the display when the drip tray and/or the waste container is full and needs to be emptied. Empty the drip tray **and** the waste container.

Remove the drip tray and the waste container while the coffee machine is switched on. Otherwise the message Empty the drip tray and the waste container will appear in the display even though the drip tray and/or the waste container are not filled to the maximum level.

- Pull the drip tray carefully out of the machine.

- Empty the drip tray **and** the waste container.

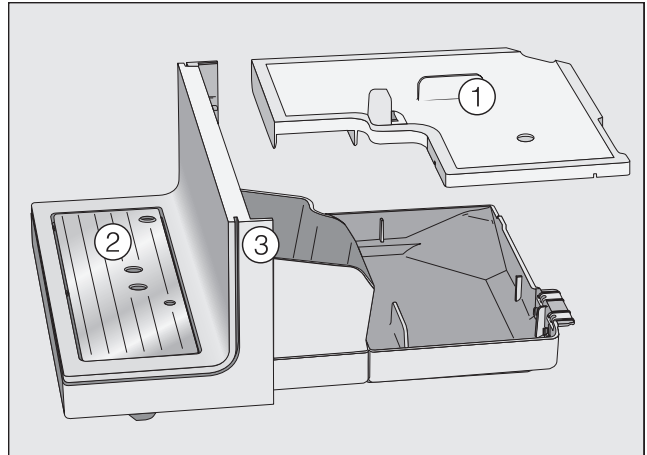

- Remove the drip tray cover ①, the drip tray ② and the lower panel ③.

Clean the lower panel by hand only using hot water, a little washing up liquid and a soft cloth. All other parts are dishwasher-safe.

- Clean all parts thoroughly.

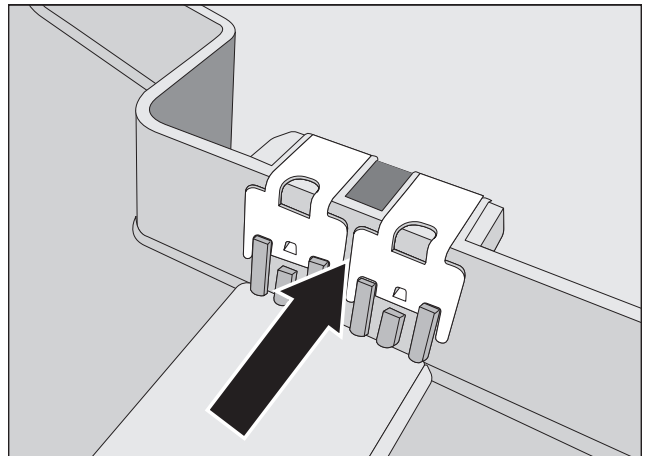

- Clean the contacts (metal discs) and the space between them carefully. Dry everything thoroughly.

The contacts will not be able to detect that the drip tray is full if they are damp or dirty. Check the contacts and the area around them once a week.

- Clean the inside of the machine underneath the drip tray.
- Replace the waste container, the lid and the lower panel **before** pushing the drip tray back into the coffee machine. Make sure the drip tray has been pushed right into the machine as far as it will go.

Cleaning the drip tray cover

- Remove the drip tray cover.
- The drip tray cover can be cleaned in the dishwasher, or by hand using warm water and a little washing-up liquid.
- Dry the drip tray.

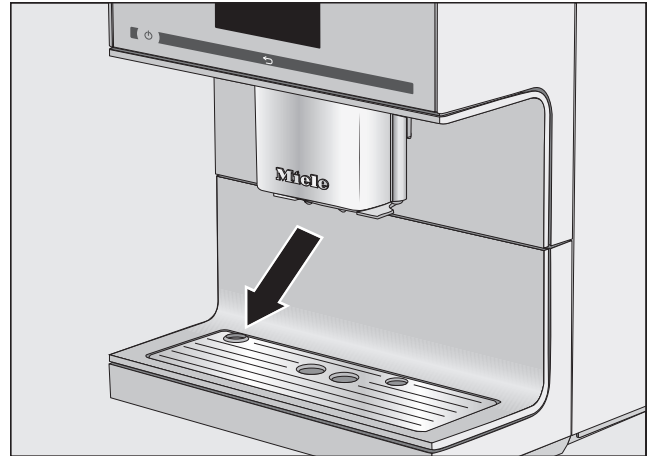

- Refit the drip tray. Make sure that the drip tray cover is correctly fitted (see picture).

Cleaning and care

Cleaning the water container

Clean the water container every day. You can clean the water container in the dishwasher once a week.

Make sure that the valve, the underside of the water container and the surface the water container sits on are clean. Otherwise, the water container will not sit correctly.

- Remove the water container.
- The water container can be cleaned in the dishwasher, or by hand using hot water and a little washing-up liquid. After cleaning, dry the water container.
- Carefully clean and dry the surface the water container sits on, taking special care to clean the recesses properly.
- Push the water container back into the appliance.

Please note that the automatic descaling programme will only work if the water container has been filled and correctly fitted in the machine.

Removing and cleaning the water container filter

Clean the water container filter once a month.

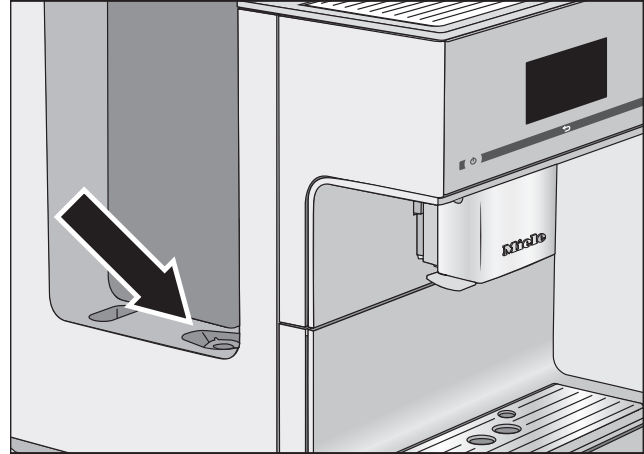

The water container filter is located under the water container.

- Open the lid on the left and remove the water container.

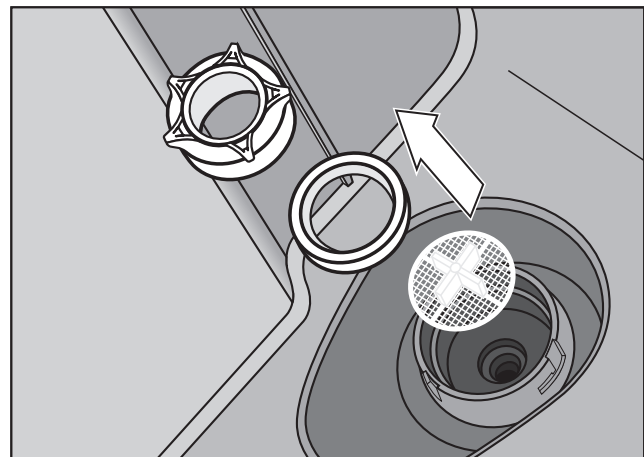

- Unscrew the cap. Remove the seal and the filter.
- Clean all parts thoroughly. Rinse all parts carefully under running water.
- Then replace the filter (with the cross facing upwards) and then the seal. The opening of the seal should face upwards. Finally screw the cap back on tightly.
- Push the water container back into the appliance.

Cleaning the central spout with integrated cappuccinatore

With the exception of the stainless steel cover, all parts of the central spout should be cleaned in the dishwasher at least **once a week**. This will remove coffee deposits and milk residues effectively.

Clean the central spout stainless steel cover **by hand only** using warm water and a little washing-up liquid.

Start in the Drinks menu.

If the central spout is in the uppermost position it cannot be dismantled. The central spout must be moved into the maintenance position to do this.

- Touch ↶ for 3 seconds.

The central spout will move into the maintenance position.

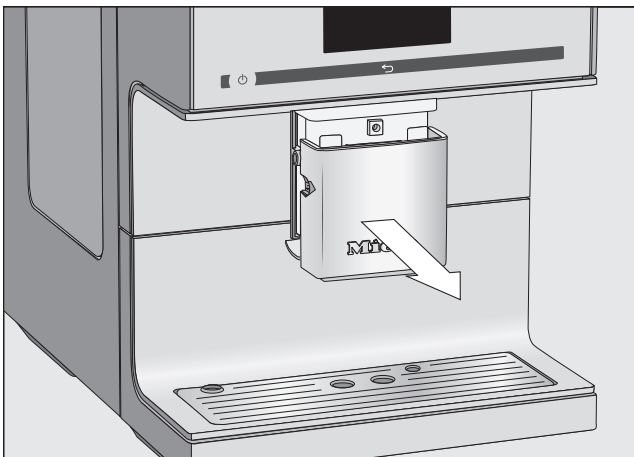

- Carefully pull the stainless steel cover off.

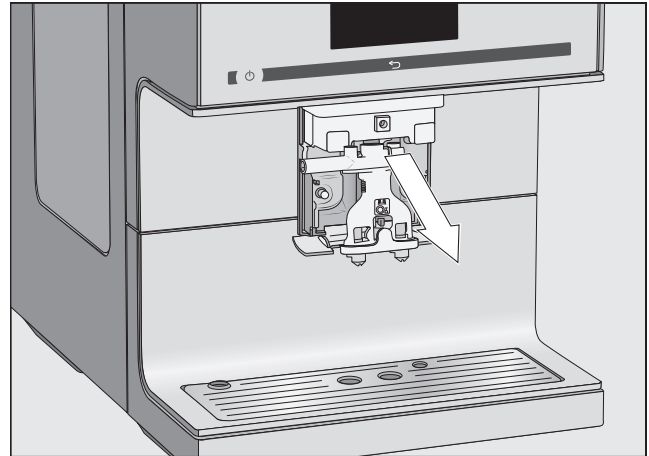

- Remove the dispensing unit to the front.

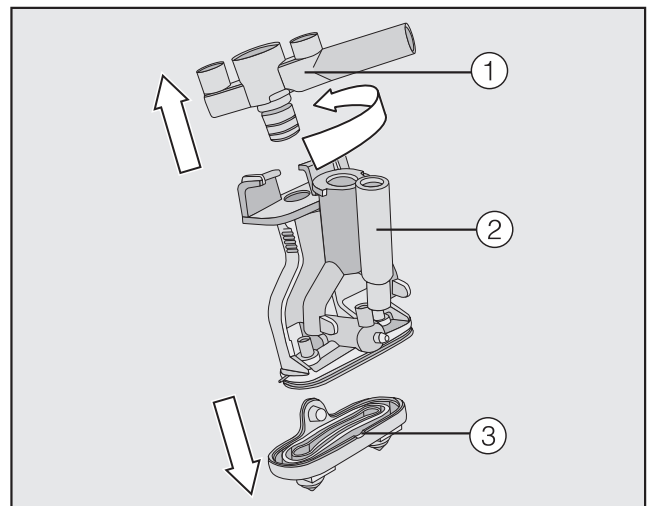

- Twist off the upper section with the holder for the milk pipework ① and pull it off. Then pull the Y-shaped piece ② off. Remove the dispensing spouts ③.
- Clean all parts thoroughly.

Cleaning and care

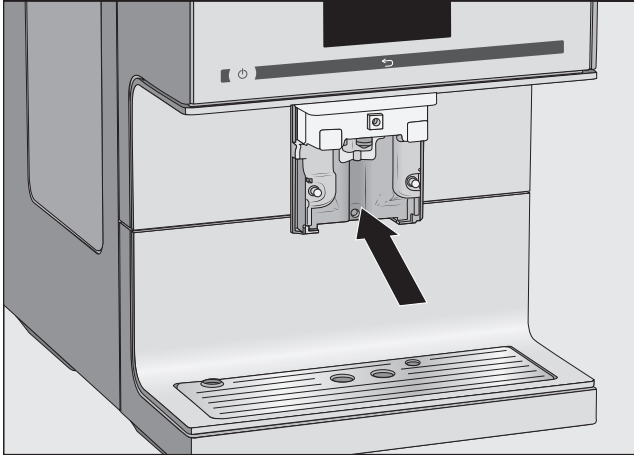

- Clean the surfaces of the central spout with a damp cloth.

Clean any blockages in the milk pipework under running water with the special brush supplied:

- Insert the brush in the pipework. Move it back and forth until all milk residue has been removed.

Reassembling the central spout

The dispensing unit is easier to reassemble if the individual parts are dampened with water beforehand.

- Fit the dispensing unit back together. Push the spouts ③ firmly back onto the dispensing unit.

Make sure that all parts are tightly connected to one another.

- Push the dispensing unit back into the central spout and replace the stainless steel cover.
- Touch *OK*.

Tip: If the coffee machine is switched off, the central spout components can be removed and cleaned at any time.

Removing and cleaning the cup sensor

The cup sensor is located under the central spout.

Clean the cup edge sensor daily by hand with warm water and a little washing-up liquid.

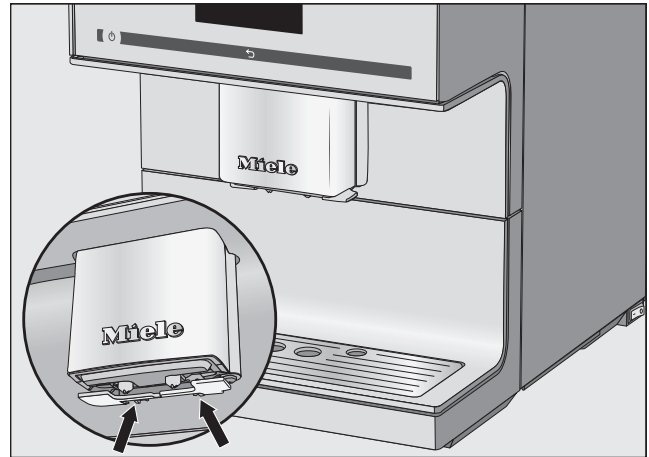

- Press the two retainers together (see arrows).

The cup edge sensor is released.

- Clean the cup edge sensor.

Refitting:

- Press the cup edge sensor from below into the holder on the central spout.

Cleaning the stainless steel milk flask

The stainless steel milk flask should be taken apart and cleaned every day.

- Clean all parts **by hand only** using hot water and a little washing-up liquid. Use a small cleaning brush to remove milk residue from the milk pipework if necessary.
- Rinse all parts thoroughly under running water.

Residual washing-up liquid can affect the taste of milk and the quality of the milk froth.

- Dry all parts thoroughly.
- Reassemble the stainless steel milk flask.

Cleaning the milk pipework manually or using the maintenance programme

 Risk to health due to inadequate cleaning
Milk naturally contains bacteria. Heat and moisture inside the coffee machine can cause these bacteria to multiply, e.g. milk residues can go off and pose a risk to health.
Clean all components in which milk is transported on a regular basis.

The milk pipework must be cleaned at least once a week. A message in the display will prompt you when this needs to be done.

- Confirm the message with *OK*.

When you confirm the message *Clean the milk pipework* with *OK*, the internal counter for the cleaning interval will be reset. You will **not** be reminded again.

There are two options for cleaning the milk pipework:

- You can remove and dismantle the central spout with its integrated cappuccinatore and either wash it in the dishwasher or by hand with warm water and a little washing-up liquid (see “Cleaning the central spout with integrated cappuccinatore”).
- Or you can clean the milk pipework using the *Clean the milk pipework* maintenance programme together with the Miele Cleaning agent for milk pipework (see “Cleaning the milk pipework”).

Tip: In addition to your weekly cleaning routine we recommend carrying out the alternative cleaning procedure once a month. For example if you manually clean the machine once a week, then you should run the maintenance programme once a month. This combination will ensure optimum cleaning of the milk pipework.

Cleaning and care

Clean the bean container

 Danger of injury on the moving grinder!

If you reach into the grinder or objects such as a spoon are left in the grinder and a grinding process is unintentionally started, you could be injured.

Switch off the machine and disconnect it from the power supply before cleaning the bean system.

Coffee beans contain oils which can deposit on the walls of the bean container and hinder the flow of the beans. Therefore, clean the bean container regularly with a soft cloth.

Tip: Use a vacuum cleaner to remove any coffee residues from the bean container.

- Take the lid off the bean container.
- Remove any coffee beans.
- Clean the bean container with a dry, soft cloth.

The bean container can now be refilled.

- Replace the lid.

Tip: If required, you can clean the lid of the bean container **by hand** with warm water and a little washing-up liquid. Dry the lid thoroughly before refitting it on the bean container.

Ground coffee drawer cleaning

Clean the ground coffee drawer and chute for ground coffee regularly, e.g. when you degrease the brew unit.

- Open the appliance door.

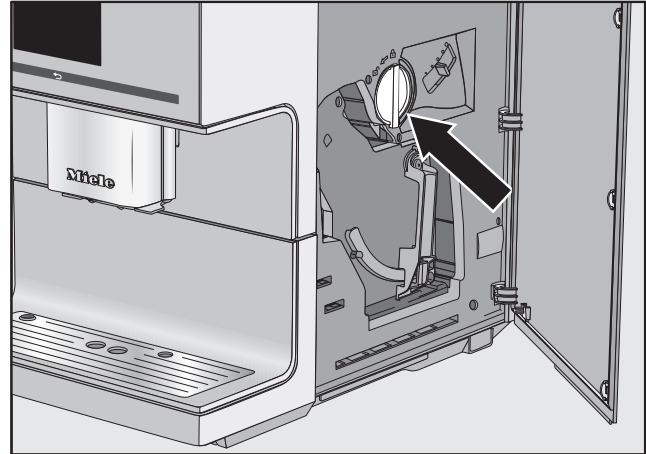

- Turn the handle (see arrow) to the left to remove the ground coffee drawer.
- The ground coffee drawer can be cleaned in the dishwasher, or by hand using hot water and a little washing-up liquid. Dry the ground coffee drawer.
- Remove any ground coffee residues from the ground coffee chute with a soft, dry cloth.
- Refit the ground coffee drawer. Turn the handle to the right to close the ground coffee chute.
- Close the appliance door.

Cleaning the housing

If soiling is allowed to stay on for a long time or there is contact with unsuitable cleaning agents, surfaces can alter or discolour.

Remove any soiling immediately. Make sure that water cannot get behind the display.

Ensure that any splashes of descaling solution are wiped up immediately.

- Switch the coffee machine off.
- Clean the front with a clean soft sponge and a solution of warm water and a little washing-up liquid. Dry all parts with a soft cloth.

Tip: You can also clean the appliance front with the Miele all purpose microfibre cloth.

Maintenance programmes

The coffee machine has the following maintenance programmes:

- Rinsing the machine
- Rinsing the milk pipework
- Cleaning the milk line
- Degreasing the brew unit
- Descaling the machine

Carry out the relevant maintenance programme when the prompt to do so appears in the display. You can also start maintenance programmes at any time so that the coffee machine does not prompt mandatory cleaning at an inconvenient time.

Please note that each maintenance programme must be carried through to the end and cannot be cancelled.

Opening the “Maintenance” menu

Start in the Drinks menu.

- Touch ↶.
- Select Maintenance.

You can now select a maintenance programme.

Cleaning and care

Rinsing the machine

After a coffee has been dispensed, the machine is rinsed before it switches off. This removes any residual coffee.

You can also rinse the milk pipework manually.

Start in the Drinks menu.

- Touch ↩.
- Select Maintenance and then Rinse the machine.

You may also be prompted to insert the end of the milk tube into the drip tray.

Rinsing the milk pipework

The milk pipework can become blocked by milk residues. The milk pipework should therefore be rinsed regularly. If a drink has been made using milk, the prompt to place the milk pipework into the drip tray will appear at the latest when you switch the machine off.

You can also rinse the milk pipework manually.

Start in the Drinks menu.

Tip: Place a suitable container underneath the central spout.

- Touch ↩.
- Select Maintenance and then Rinse the milk pipework.

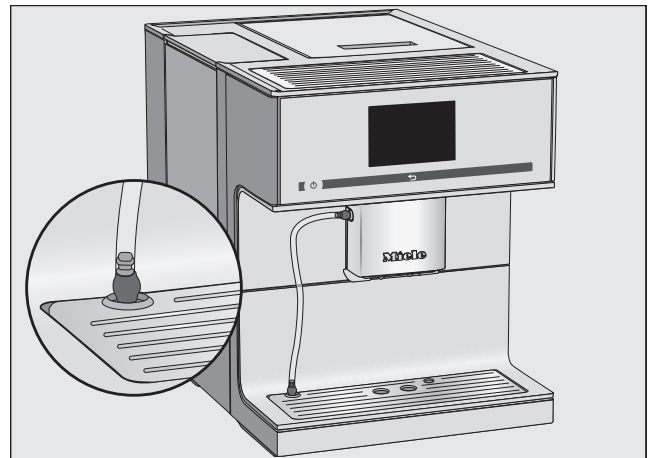

- Place the end of the milk tube into the aperture in the drip tray cover.
- Confirm with *OK*.

The milk pipework will now be rinsed.

Cleaning the milk line

For optimal cleaning results, we recommend Miele Cleaning Agent for milk pipework. The Cleaning Agent for milk pipework has been specially developed for use with Miele coffee machines and prevents subsequent damage.

It is available to order via the Miele webshop or directly from Miele (see the end of this booklet for contact details).

The Clean the milk pipework maintenance programme lasts for approx. 10 minutes.

Start in the Drinks menu.

- Touch ↩.

The cleaning process cannot be cancelled. It must be completed through to the end.

- Select Maintenance and then Clean the milk pipework.

The process will start.

- Follow the instructions in the display.

Insert milk pipe in cleaning agent will appear in the display.

Preparing the cleaning solution:

- Dissolve the cleaning agent in a container with 200 ml of lukewarm water. Stir the solution with a spoon until the powder has fully dissolved.

Carrying out the cleaning process:

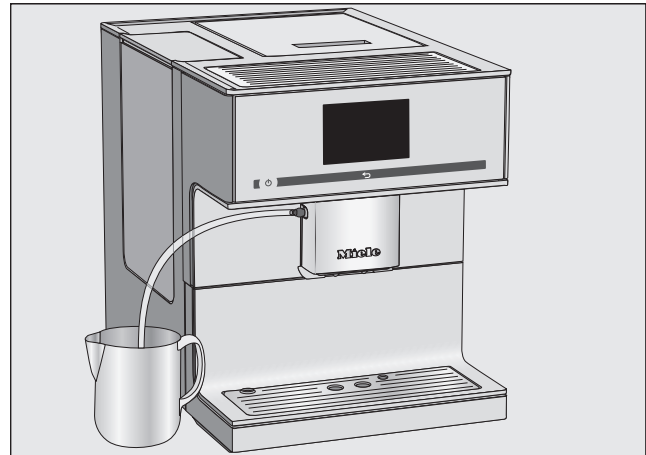

- Place the container next to the machine and hang the milk tube in the solution. Make sure it is placed sufficiently far into the cleaning solution.
- Touch OK.
- Follow the further instructions given in the display.

The cleaning process is finished at the end of the rinsing cycle.

Cleaning and care

Degreasing the brew unit and cleaning inside

Depending on the natural oil content of the coffee used, the brew unit can become blocked quite quickly. It must be degreased regularly in order to ensure aromatic coffee and trouble-free operation of the coffee machine.

We recommend using Miele cleaning tablets to clean the brew unit. These have been specially developed for use with Miele coffee machines and prevent subsequent damage.

Miele cleaning tablets can be ordered via the Miele webshop, from Miele (see back cover for contact details) or from your Miele dealer.

The maintenance programme for degreasing the brew unit lasts for approx. 12 minutes.

After 200 portions have been dispensed, Degrease the brew unit will appear in the display.

- Confirm the message with *OK*.

The message will appear at regular intervals. Once the maximum possible number of portions has been reached, the coffee machine will lock out.

You can switch the coffee machine off if you do not want to carry out the maintenance programme at this point in time. You will only be able to make coffee drinks again once the the brew unit has been degreased.

Degrease the brew unit when prompted to do so.

No drinks can be made and Degrease the brew unit appears in the display.

The maintenance programme cannot be cancelled. It must be completed through to the end.

- Touch *OK*.

The maintenance programme will then start.

- Follow the instructions in the display.

Cleaning the brew unit and interior

To ensure good tasting coffee and to prevent the formation of microbes in the machine, remove and clean the brew unit under running water once a week.

The moving parts of the brew unit are lubricated. Cleaning agents and washing-up liquid will damage the brew unit.

Clean the brew unit by hand only under warm running water. **Do not use washing-up liquid or any other cleaning agent.**

- Open the appliance door.

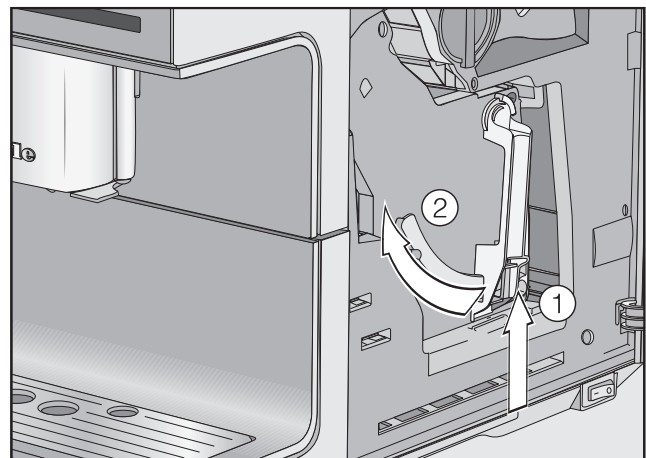

- Press and hold the button under the brew unit handle ① and, whilst doing so, turn the handle to the left ②.
- Carefully pull the brew unit out of the coffee machine.

Cleaning and care

When you have removed the brew unit, do **not** change the position of the handle on the brew unit. Otherwise the brew unit cannot be inserted.

- Clean the brew unit **by hand under warm running water** without using cleaning agent or washing-up liquid.

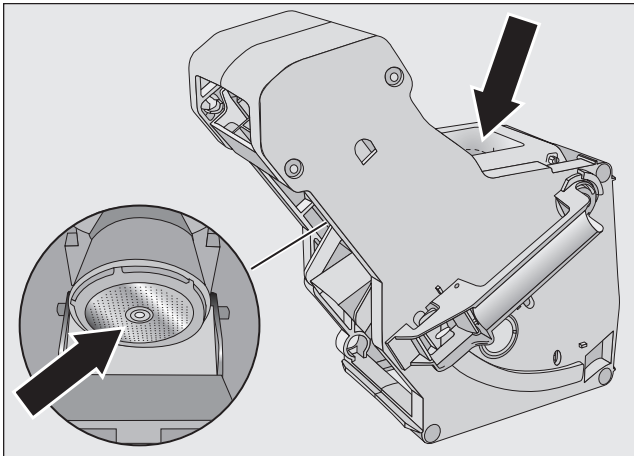

- Wipe any remaining coffee off the two filters (see arrows).
- Dry the funnel to prevent ground coffee sticking to it the next time a coffee is made.

 Risk to health due to inadequate cleaning

Damp coffee residues in the interior of the machine can go mouldy and pose a risk to health.

Remove coffee residues regularly and clean the interior of the machine.

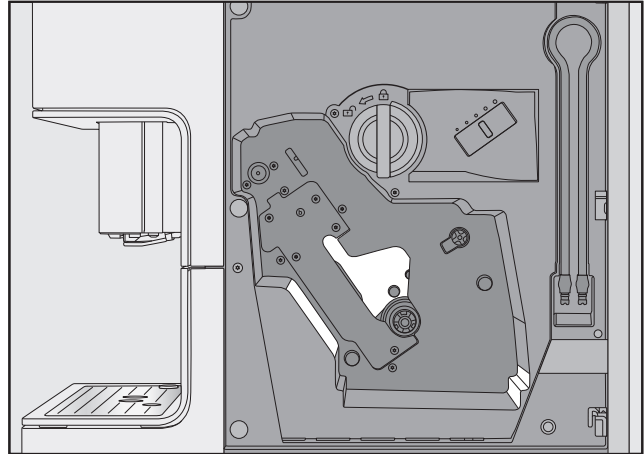

- Clean the inside of the coffee machine. Make sure that the areas highlighted in the illustration are cleaned especially well.

Tip: Use your vacuum cleaner to remove dry ground coffee residues.

The following will appear in the display:
Fit the brew unit with a cleaning tablet in it.

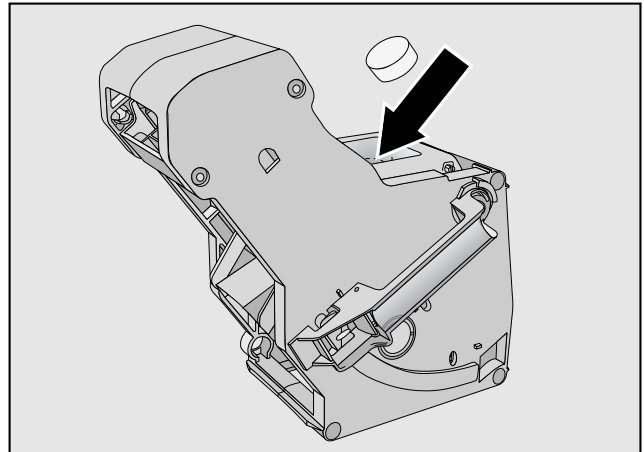

- Drop a cleaning tablet into the top of the brew unit (arrow).
- Push the brew unit with cleaning tablet back into the coffee machine, making sure it goes in straight.

Cleaning and care

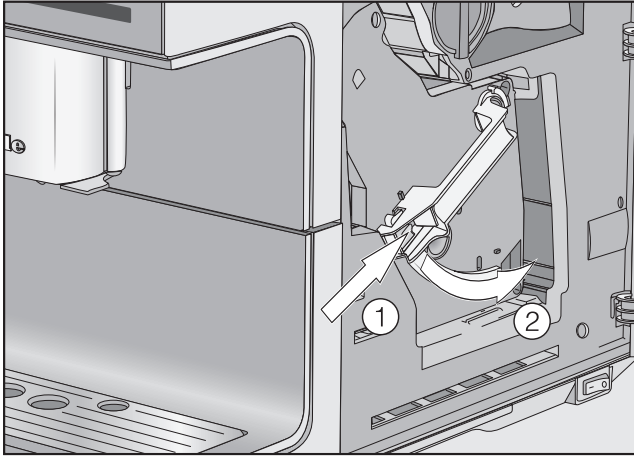

- Press the button under the handle of the brew unit ① and, whilst doing so, turn the handle to the right ②.
- Close the appliance door.
- Follow the further instructions given in the display.

The cleaning process is finished at the end of the rinsing cycle.

Descaling the machine

Risk of damage from spilt descaling solution.

Sensitive surfaces and/or natural floors can suffer damage.

Wipe up any spillages of descaling agent immediately.

Limescale builds up in the coffee machine through use. How often the appliance needs to be descaled will depend on the water hardness level in your area. Limescale must be removed regularly.

Depending on how you use your machine and the water hardness level in your area, occasionally you will need to descale your machine manually in addition to automatic descaling.

If a descaling cartridge is **not** fitted, an **empty** cartridge is fitted or an **expired** cartridge is fitted, the machine needs to be descaled regularly using the **Descal the machine** maintenance programme.

The appliance will guide you through the descaling process. Various messages will appear in the display, e.g. you will be prompted to empty the drip tray or fill the water container.

You need **1** descaling tablet for the descaling process. The process takes approx. 12 minutes.

The coffee machine prompts you when it needs to be descaled. Number of drinks until the machine must be descaled: 50 will appear in the display. The remaining number of drinks that can be made before descaling will show in the display after each drink.

- Confirm the message with **OK**.

When the number of remaining portions reaches 0, the coffee machine will lock out.

Descal the machine will appear in the display.

You can switch the coffee machine off if you do not want to carry out the descaling programme at this point in time. You can not make any drinks until the machine has been descaled.

Descaling after prompt appears in the display

Descal the machine appears in the display.

Descaling cannot be cancelled once it has started. It must be completed through to the end.

- Touch **OK**.

The process will start.

- Follow the instructions in the display.

When Fill the water container to the  symbol with descaling agent and lukewarm water and place it in the machine. **appears** in the display, proceed as follows.

Make up the descaling solution

We recommend using Miele descaling tablets for optimum results. These have been specially developed for use with Miele coffee machines and prevent subsequent damage.

Other descaling agents, which contain other acids besides citric acid and/or other undesirable substances, such as chlorides for example, could damage the coffee machine. Moreover, the descaling effect required could not be guaranteed if the descaling solution was not of the appropriate concentration.

Miele descaling tablets are available to order via the Miele webshop, from Miele (see back cover for contact details) or from your Miele dealer.

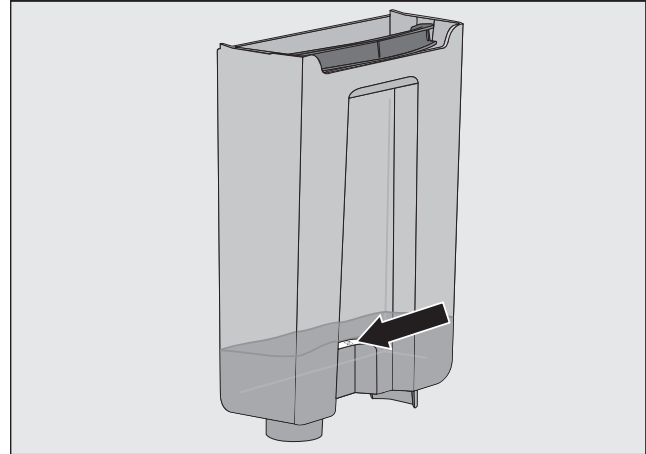



- Fill the water container to the descaling symbol  with lukewarm water.
- Place **1** descaling tablet in the water.

Follow the instructions for the mixing ratio carefully. It is important to fill the water container with the correct amount of water. Otherwise the descaling process will be cancelled prematurely.

Carrying out descaling

- Push the water container back into the appliance.
- Follow the further instructions given in the display.

When Rinse the water container and fill it to the  symbol with fresh tap water **appears** in the display:

- Remove the water container and rinse it thoroughly with clean water. Ensure that **no** descaling solution residue remains in the water container. Fill the water container to the descaling symbol  with fresh tap water.

Cleaning and care

The descaling process is complete at the end of the rinsing process. You can now make drinks again.

Risk of damage from spilt descaling solution.

Sensitive surfaces and/or natural floors can suffer damage.

Wipe up any spillages of descaling agent.

When handling a cartridge which has already been filled with water, ensure that the descaling solution does not come into contact with sensitive surfaces.

To ensure the longevity of components and a consistent environment free of limescale, the coffee machine needs to be manually descaled from time to time. The intervals are determined by your usage behaviour and the water hardness level of your area. If you make a lot of coffees with milk, for example, you will need to descale the coffee machine more frequently with the descaling tablets.

The coffee machine has an automatic maintenance programme for descaling the machine. For automatic descaling, a Miele descaling cartridge is fitted at the back of the coffee machine. The coffee machine will automatically determine the days when to carry out automatic descaling based on the usage pattern. Automatic descaling takes approx. 4 hours, including the activation phase.

You can set the time for automatic descaling to start using the Descaling timer.

Water is mixed with the descaling agent to create a solution for automatic descaling. This descaling solution is then pumped through the pipework of the coffee machine. After the activation phase the solution is then rinsed out of the pipework and the machine can then be used as normal for making drinks.

During automatic descaling you will hear pumping and rinsing noises at frequent intervals even though the appliance is switched off and the display is dark.

If you do not make any drinks, automatic descaling will not be started.

Please note before and during automatic descaling:

The coffee machine must be ready to use and the following conditions must be met:

- A descaling cartridge which is ready to use is fitted.
- The coffee machine is connected to the electricity supply. The coffee machine must **not** be disconnected from the electricity supply during automatic descaling.
- The drip tray, brew unit and central spout are inserted.
- The water container is inserted and is filled with water at least up to the  descaling mark.
- Carry out the instructions which appear in the display before switching off, e.g. Empty the drip tray.
- If you have made drinks with milk, the milk tube must be pushed into the drip tray and when the machine is switched off, the message about this in the display confirmed with *OK*.

Automatic descaling

- The coffee machine is switched off.

The Miele descaling cartridge

Only use the Miele descaling cartridge for the automatic descaling programme.

Please note that the Miele descaling cartridge has a lifespan of approx. one year after it has been placed in the machine and filled with water for the first time. Critical for the one-year shelf life is the date on which the descaling cartridge was fitted and filled with water.

Do not use a descaling cartridge which has already been used in another Miele coffee machine. Your coffee machine will have no information about the fill level of this cartridge. The descaling effect may be insufficient and damage your coffee machine.

Do not fill the descaling cartridge with other fluids or substances.

The descaling agent comes in the form of tablets in the descaling cartridge. The cartridge is filled with water when it is placed in the machine. The tablets gradually dissolve over time.

The Miele descaling cartridge will last for 7 to 12 months of automatic descaling, depending on how often the coffee machine is used.

A prompt will appear in the display shortly before the cartridge is depleted, reminding you that it needs to be replaced. Confirm the message with **OK**. After this first message, six more descaling programmes are possible.

The descaling cartridge is available to order from the Miele online shop or directly from Miele (see back cover for contact details).

If a descaling cartridge is **not** fitted, an **empty** cartridge is fitted or an **expired** cartridge is fitted, the machine needs to be descaled using the **Descal the machine** maintenance programme. To do this, the appropriate descaling agent is required (see "Cleaning and care - Descaling the machine").

The descaling cartridge can remain fitted even if the machine is not used for a long time. Remove the cartridge before transporting the coffee machine. Please note:

- Once filled with water, the descaling cartridge has a maximum shelf life of three weeks outside of the machine.
- It should be transported with care and upright. Avoid shaking it. Shaking or turning upside down reduces the shelf life or damages the cartridge.
- The cartridge should be stored upright, in a dark place and at room temperature (16 - 38 °C).

Automatic descaling

Fitting and removing a descaling cartridge

Risk of damage from spilt descaling solution.

Sensitive surfaces and/or natural floors can suffer damage.

When handling a cartridge which has already been filled with water, ensure that the descaling solution does not come into contact with sensitive surfaces.

The coffee machine is switched on. Only then will the appliance detect the descaling cartridge.

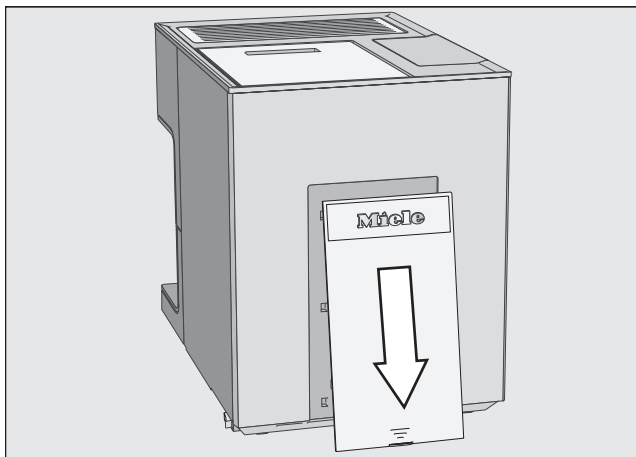

- Slide the cover at the back of the coffee machine downwards.

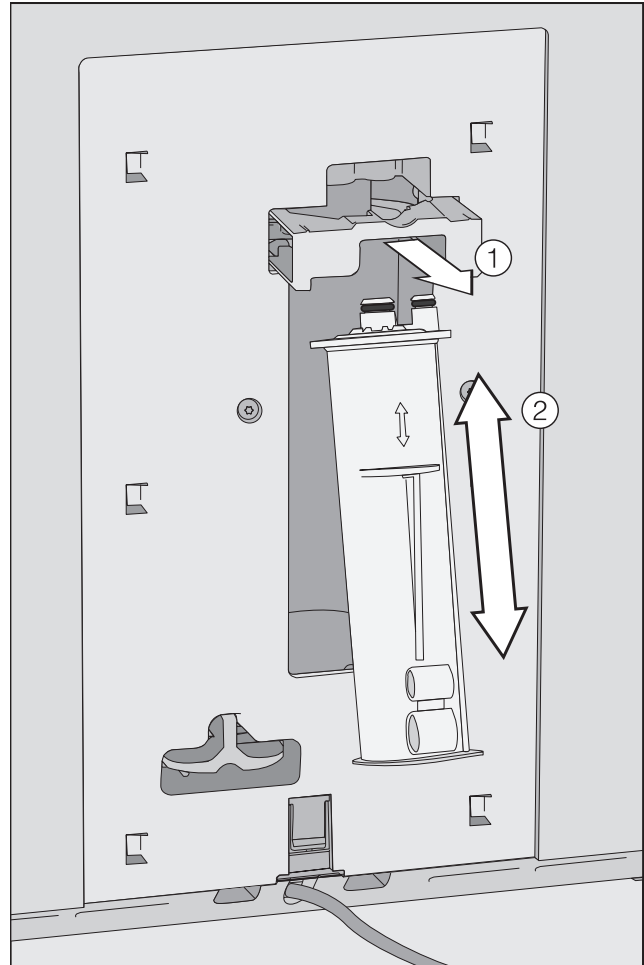

- Pull the cartridge holder ① forwards. There is already a cartridge fitted.
- Remove the cartridge ②.

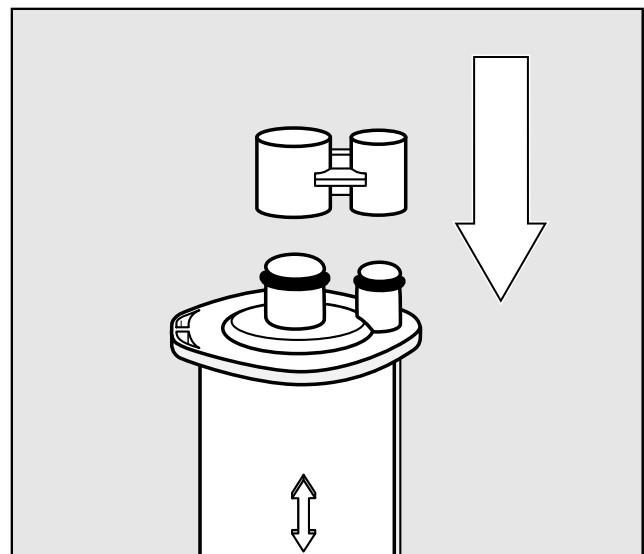

- Seal the cartridge with the cap.

Automatic descaling

The cap is located on the cartridge. Release it by snapping it off.

- Dispose of the spent cartridge with your household waste.

Fit the descaling cartridge

- Insert the cartridge ② and push it upwards as far as it will go.
- Push the cartridge holder ① back and then close the cover.
- Follow the instructions in the display.

The next time the coffee machine is switched off, the descaling cartridge will also fill with water when the machine is rinsed. You will hear water being pumped into the cartridge at frequent intervals.

If you do not want to fit a descaling cartridge, the system must be sealed with the plug. Messages such as “Fit a new descaling cartridge” will be not displayed.

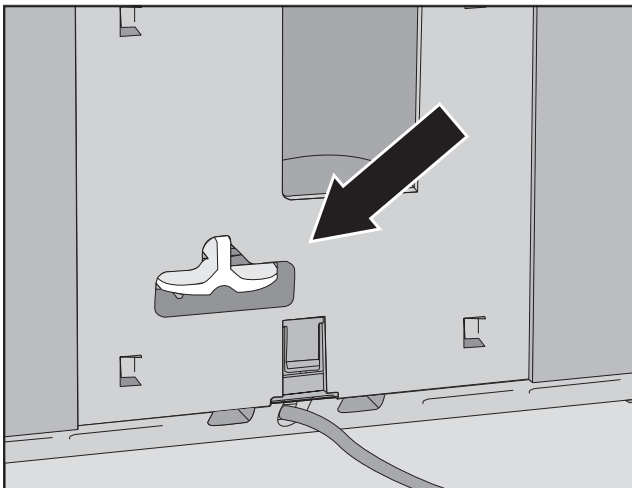

- Insert the adapter in place of the cartridge.

Set the start time for automatic descaling (Descaling timer).

You can set the daily start time for automatic descaling as you wish. The coffee machine must be switched off for the duration of the activation phase (approx. 4 hours). For this reason, it is best to set an evening time or a regular time during which you are not at home during the day.

Start in the Drinks menu.

- Touch ↶.
- Select Settings  and then Timer.
- Select Descaling timer.
- Set the start time you want and touch *OK*.

The start time is saved. From now on automatic descaling will commence at the desired time each day.

Many malfunctions and faults that can occur in daily operation can be easily remedied. Time and money will be saved because a service call will not be needed.

The following guide may help you to find the reason for a malfunction or a fault, and to correct it.

Messages in the display

Error messages must be confirmed with *OK*, otherwise the message can reappear in the display even though the problem has been remedied.

Follow the instructions which appear in the display to remedy the problem.

If after this, the fault message appears in the display again, contact Miele Service.

Problem	Cause and remedy
F1, F2, F80, F82	There is an internal fault. ■ Switch the coffee machine off with the On/Off sensor ①. Wait for approx. 1 hour before switching it back on again.
F41, F42, F74, F77, F225, F226, F235, F236	There is an internal fault. ■ Switch the machine off with the On/Off sensor ①. Wait for approx. 2 minutes before switching it back on again.

Problem solving guide

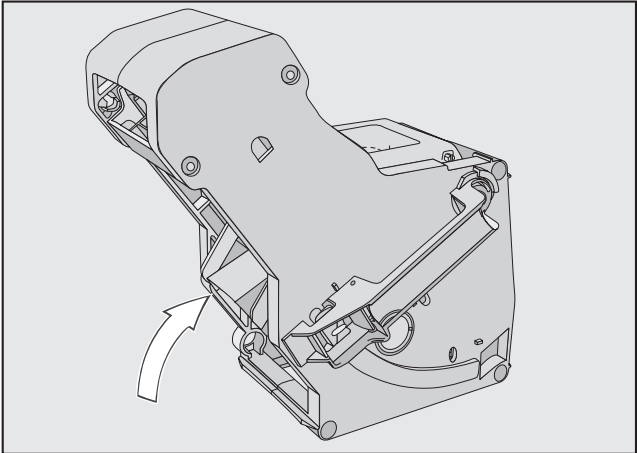
Problem	Cause and remedy
<p>F73 or Check the brew unit</p>	<p>The brew unit cannot be positioned correctly.</p> <ul style="list-style-type: none">■ Switch the machine off with the On/Off ⓪ sensor.■ Remove the brew unit and clean it by hand.  <ul style="list-style-type: none">■ Push the coffee ejector of the brew unit into the correct position.■ Do not fit the brew unit. Close the service panel and switch the coffee machine on with the On/Off ⓪ sensor. <p>This will initialise the brew unit motor and put it back into the start position.</p> <ul style="list-style-type: none">■ When Insert the brew unit appears in the display, put the brew unit back in the machine. Close the appliance door. <p>If the message appears again, reduce the amount of coffee and/or select a finer grinder setting. Some types of coffee have a much higher grinding volume.</p>

Problem solving guide

Problem	Cause and remedy
F233	<p>The cup sensor is not inserted or is incorrectly inserted.</p> <p>The stainless steel cover of the central spout was not fitted properly, e.g. is tilting forwards slightly.</p> <p>If the central spout is moving upwards and the cup sensor is bumped, e.g. with a cup, the cup sensor loses its reference position.</p> <ul style="list-style-type: none">■ Confirm the message with <i>OK</i>.■ Switch the machine off with the On/Off ⓘ sensor. Wait for approximately 2 min before switching the machine back on again.■ Refit the cup sensor.■ Refit the stainless steel cover. Make sure the cover is seated correctly.

Problem solving guide

Unusual performance of the coffee machine

Problem	Cause and remedy
The lighting remains off after the coffee machine has been switched on.	The lighting has been switched off. ■ Switch the lighting on (see “Settings - Lighting”).
	The lighting is faulty. ■ Call Service.
The display remains dark when the coffee machine is turned on using the On/Off button ①.	The On/Off button ① was not held for long enough. ■ Touch and hold the On/Off ① sensor for at least three seconds.
	The plug is not inserted in the socket correctly. ■ Insert the plug into the socket.
	The fuse has tripped because the coffee machine, voltage, or another appliance is defective. ■ Switch off at the wall socket and remove the plug. ■ Contact a qualified electrician or Miele.
The coffee machine turns off suddenly.	The switch-off time programmed using the timer has been reached. ■ If required, you can select a new switch-off time (see “Settings – Timer”).
	The plug is not inserted in the socket correctly. ■ Insert the plug into the socket.
The coffee machine is switched on. The lighting switches off suddenly.	The lighting switches off automatically if the coffee machine has not been used for some time. The automatic switch-off time cannot be changed.
The sensors do not react to touch. The coffee machine cannot be operated.	There is an internal fault. ■ Disconnect the machine from the power supply by removing the plug from the socket.

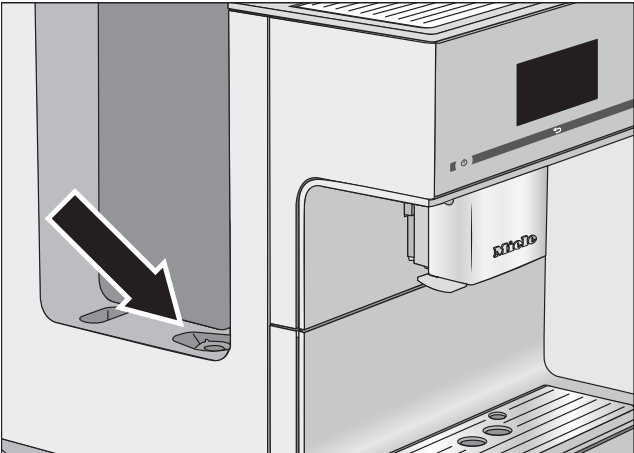
Problem	Cause and remedy
<p>The coffee machine does not switch itself on, although the <small>Switch on at</small> setting has been activated for the timer.</p>	<p>The system lock has been activated.</p> <ul style="list-style-type: none"> ■ Deactivate the system lock.
	<p>A day of the week has not been selected and/or the timer has not been activated.</p> <ul style="list-style-type: none"> ■ Check and change the timer settings.
	<p>The coffee machine was not used after being switched on automatically three times in succession (holiday mode).</p> <ul style="list-style-type: none"> ■ Switch the machine on and dispense a drink.
	<p>The coffee machine does not switch on with the <small>Switch on at timer</small> while automatic descaling is being carried out. This is not a fault. Select a different timer setting.</p>
<p>Fill and refit the water container appears in the display even though the water container is full and in the machine.</p>	<p>The water container is not in the correct position.</p> <ul style="list-style-type: none"> ■ Remove the water container and push it back in again. ■ Clean the surface underneath the water container if necessary.
	<p>During the <small>Descal</small> the machine maintenance programme the water container was not correctly filled and refitted.</p> <ul style="list-style-type: none"> ■ Fill the water container to the descaling symbol  and restart the descaling programme.
	<p>The water container filter is blocked.</p>  <ul style="list-style-type: none"> ■ Clean the water container filter (see “Cleaning and care - Removing and cleaning the water container filter”).

Problem solving guide

Problem	Cause and remedy
<p>Fill and refill the water container appears after switching on even though the container is filled and fitted in the machine. The appliance does not rinse.</p>	<p>The descaling cartridge is not fitted. The coffee machine needs descaling.</p> <ul style="list-style-type: none"> ■ Switch the machine off with the On/Off ⓘ sensor. Wait approx. one hour. ■ Switch the appliance back on again. As soon as Heating-up phase appears, touch Mainten. and then select Descal. the machine. ■ Descal. the coffee machine.
<p>Insert the drip tray and the waste container appears in the display, even though both have been inserted.</p> <p>Although the drip tray has been emptied, Empty the drip tray and the waste container appears in the display.</p>	<p>The drip tray is not in the correct position and is therefore not detected.</p> <ul style="list-style-type: none"> ■ Empty the drip tray and the waste container if necessary. ■ Reassemble all parts and push the drip tray back in the coffee machine until it clicks.
<p>The waste container is full, although the drip tray and waste container have been emptied following each reminder.</p>	<p>This is not a fault. The drip tray has probably been removed without the waste container being emptied. Removing the drip tray resets the internal counter for emptying the waste container.</p> <ul style="list-style-type: none"> ■ Always empty the waste container if you remove the drip tray.

Problem solving guide

Problem	Cause and remedy
<p>The brew unit cannot be removed.</p>	<p>The brew unit is not in the correct position because the appliance door was opened during the brewing process, for example.</p> <ul style="list-style-type: none"> ■ If necessary, move the handle on the brew unit back to the start position. Close the appliance door. ■ Switch the machine off with the On/Off (ⓘ) sensor. ■ Disconnect the coffee machine from the power supply. ■ Wait approx. one minute before reconnecting the coffee machine to the electricity supply and switching it on. <p>This will initialise the brew unit motor and put it back into the start position.</p> <ul style="list-style-type: none"> ■ If necessary, repeat these steps.
<p>Coffee is not flowing out of the central spout. Or coffee is only being dispensed via one spout.</p>	<p>The central spout has a blockage.</p> <ul style="list-style-type: none"> ■ Rinse the coffee pipework (see “Cleaning and care - Rinsing the machine”). <p>If there is still no coffee coming out, or coffee is only coming out of one side</p> <ul style="list-style-type: none"> ■ Dismantle the central spout and clean all parts carefully. ■ Make sure all parts are reassembled correctly.
<p>Neither milk nor milk froth comes out of the central spout.</p>	<p>The milk pipework is blocked.</p> <ul style="list-style-type: none"> ■ Clean the central spout, taking particular care to clean the cappuccinatore and milk pipework carefully with the cleaning brush.
<p>The display lights up but the coffee machine does not heat up and no drinks are made. The coffee machine cannot be turned off.</p>	<p>The Demo mode for demonstrating the coffee machine in the showroom has been activated.</p> <ul style="list-style-type: none"> ■ Deactivate Demo mode.

Problem solving guide

Faults with automatic descaling

Problem	Cause and remedy
After switching on, a message appears informing you that automatic descaling could not be carried out.	<p>If you have made drinks with milk, the milk tube must be pushed into the drip tray and when the machine is switched off, the message about this in the display confirmed with <i>OK</i>.</p> <p>All removable parts, such as the water container, drip tray, brew unit or central spout must be fitted.</p> <p>The water container must be filled with water at least up to the descaling symbol ☞.</p> <p>The machine door was not closed.</p> <ul style="list-style-type: none">■ Confirm the message with <i>OK</i>.■ Make sure that the coffee machine is ready to use before the next descaling process.
	<p>The coffee machine was not switched off at the start time using the On/Off ① sensor.</p> <p>The coffee machine pipework will only be filled with descaling solution when the coffee machine is switched off.</p> <ul style="list-style-type: none">■ Confirm the message with <i>OK</i>.■ Change the start time if necessary.
Descal appliance manually appears in the display even though a descaling cartridge which is ready to use is fitted. Drinks cannot be made.	<p>Depending on the water hardness level in your area and your usage behaviour, the coffee machine needs to be descaled using the maintenance programme occasionally.</p> <p>For this you will need to use Miele descaling tablets.</p> <ul style="list-style-type: none">■ Descale the coffee machine using the maintenance programme (see “Cleaning and care - Descaling the appliance”).

Unsatisfactory results

Problem	Cause and remedy
The coffee is not hot enough.	The cup has not been pre-heated. The smaller the cup and the thicker its sides, the more important it is to pre-heat it. <ul style="list-style-type: none"> ■ Pre-heat the cups, e.g. using the cup heating (depending on model).
	The brewing temperature has been set too low. <ul style="list-style-type: none"> ■ Set a higher brewing temperature.
	The filters in the brew unit are blocked. <ul style="list-style-type: none"> ■ Remove the brew unit and clean it by hand. ■ Degrease the brew unit.
Drinks are being dispensed from the central spout considerably more slowly. The heating-up time is getting longer and the coffee machine is not performing properly.	The coffee machine needs descaling. If you use hard water (> 20 °dH / 3.6 mmol/l) or if the coffee machine is used intensively, it may be necessary to descale the machine manually more frequently. <ul style="list-style-type: none"> ■ Run the Descal the machine maintenance programme. You will need one descaling tablet.
The consistency of the milk froth is unsatisfactory.	The milk temperature is too high. Good milk froth can only be achieved with cold milk (below 10°C). <ul style="list-style-type: none"> ■ Check the temperature of the milk in the milk flask.
	The milk pipework is blocked. <ul style="list-style-type: none"> ■ Clean the central spout with integrated cappuccinatore and the milk pipework with the cleaning brush supplied.
The coffee grinder makes a louder noise than usual.	The coffee bean container has become empty during the grinding process. <ul style="list-style-type: none"> ■ Fill the coffee bean container with fresh beans.
	There may be foreign objects such as plastic or stones in amongst the coffee beans. <ul style="list-style-type: none"> ■ Switch the coffee machine off immediately. Call Service.

Problem solving guide

Problem	Cause and remedy
The crema on the coffee or espresso is not as it should be.	The grinder setting is not correct. ■ Set the grinder to a finer or coarser setting.
	The brew temperature is too high for the type of coffee being used. ■ Set a lower brewing temperature.
	The coffee beans are no longer fresh. ■ Add fresh beans to the coffee bean container.
The coffee tastes weak. The coffee grounds in the waste container are sludgy and grainy.	Insufficient coffee beans are getting into the grinder and less ground coffee is being brewed. If you have used a dark roast, this type of coffee bean is often more oily. These oils can cling to the inside of the coffee bean container and hinder the flow of beans. ■ Make a coffee and observe whether the coffee beans drop into the coffee bean container. ■ Clean the coffee bean container more often if you are using a darker, more oily bean. Try other types of coffee bean which are less oily.

After sales service and warranty

Contact in case of malfunction

In the event of any faults which you cannot remedy yourself, please contact your Miele Dealer or Miele Service.

Contact information for Miele Service can be found at the end of this document.

Please note that telephone calls may be monitored and recorded for training purposes and that a call-out charge will be applied to service visits where the problem could have been resolved as described in this booklet.

Please quote the model and serial number of your appliance when contacting Miele. This information can be found on the data plate.

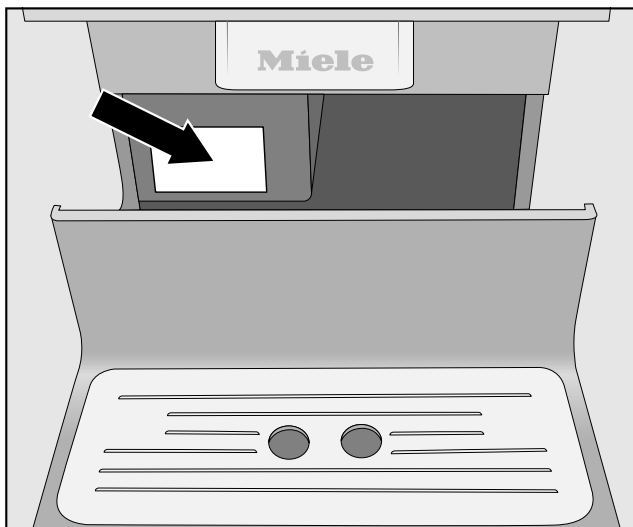

Warranty

For information on the appliance warranty specific to your country please contact Miele. See back cover for address.

In the UK, your appliance warranty is valid for 2 years from the date of purchase. However, you must activate your cover by calling 0330 160 6640 or registering online at www.miele.co.uk.

Transporting the machine

If you are not going to use the coffee machine for an extended period of time, e.g. whilst on holiday, or if it needs to be moved, a number of procedures will need be carried out to ensure its safety.

- Empty and clean the coffee bean container
- Empty and clean the water container
- Evaporate the coffee machine
- Remove the descaling cartridge and insert the adapter.
- Clean the inside of the machine
- Pack the machine securely

Evaporate

The coffee machine pipework should be evaporated before it is stored for a long period of time or transported any distance - particularly at temperatures below freezing.

Evaporating the machine involves removing all traces of water from the system to prevent the risk of water and frost damage.

Start in the Drinks menu.

 **Danger of burning and scalding on the dispensing spouts.**
Hot steam can cause scalding.
Keep well away from the area underneath the spouts when hot liquids or steam are being dispensed.
Do not touch hot components.

- Touch ↶.
- Select Settings  and then Service.
- Select Evaporate and then Yes.

- Follow the instructions in the display.

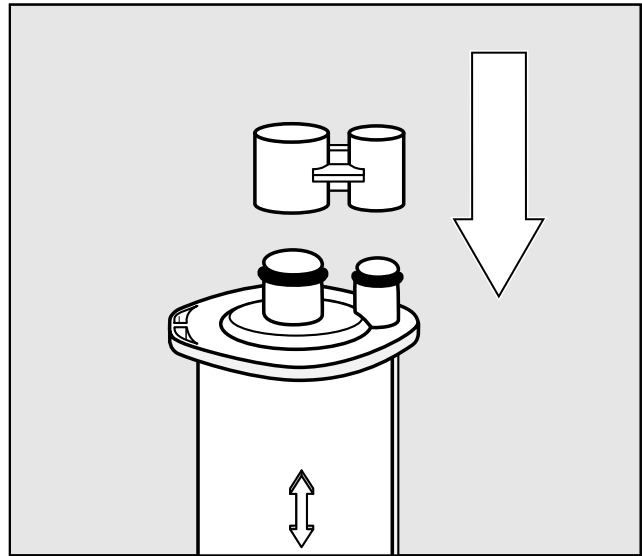

- Remove the descaling cartridge and seal it with the cap.

Once filled with water, the descaling cartridge has a max. shelf life of three weeks outside of the machine. The cartridge should be stored upright, in a dark place and at room temperature (16 - 38 °C).

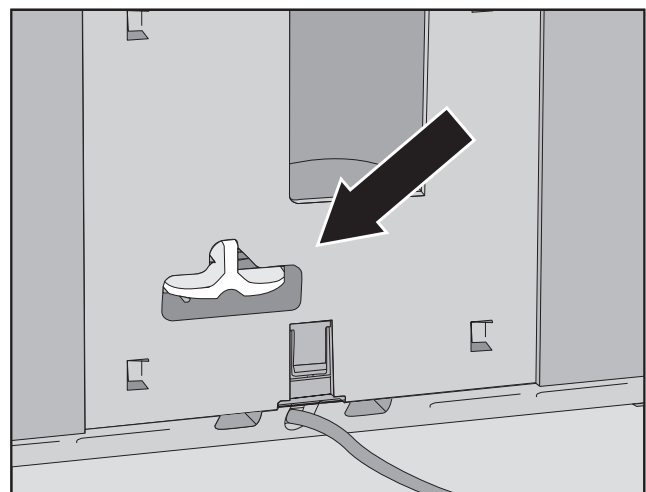

- Insert the adapter in place of the cartridge.

When the display goes out, the machine has finished evaporating.

- Clean the drip tray and waste container.

Packing the machine

The coffee machine should only be packed when it is clean and dry. Residues of coffee grounds can cause scratches on surfaces. Coffee and milk residues or water can cause a build-up of bacteria.

Use the original packaging including polystyrene blocks to pack the coffee machine.

Also pack the operating instructions so that they are available when the coffee machine is next used.

Accessories

These products and other useful accessories can be ordered via the Miele webshop, from Miele (see back cover for contact details) or from your Miele dealer.

- **Microfibre cloth**
for removing finger marks and light soiling
- **Cleaning agent for milk pipework**
for cleaning the milk system
- **Cleaning tablets**
for degreasing the brew unit
- **Miele descaling cartridge**
for automatic descaling
- **Descaling tablets**
for manual descaling
- **CJ JUG coffee flask**
Vacuum flask for coffee or tea
(capacity 1 l)
- **Miele Coffee Black Edition “One for All”**
Perfect for making Espresso, Café Crema and Coffee with milk.
- **Miele Coffee “Espresso”**
Perfect for making Espresso.
- **Miele Coffee Black Edition “Café Crema”**
Perfect for making coffee.
- **Miele Coffee “Decaf”**
Perfect for making decaffeinated coffee.

The following tips can help you save energy and money as well as care for the environment:

- Operate the coffee machine in “Eco mode” (default setting).
- Select dimmer lighting or abstain from using lighting when the appliance is switched on.
- Switch off the lighting switch-off time when the appliance is switched off.
- Switch off the clock display.
- Energy consumption may increase if you change the settings for the “timers”.

This setting uses more energy **appears in the display.**

- Switch the coffee machine off with the On/Off sensor ① if it is not going to be used for a while.
- Change the setting for the “Switch off after” timer to 20 minutes. The coffee machine will then switch itself off 20 minutes after the last drink was made or a sensor was touched.
- If you only want to pre-heat your cups occasionally, you can switch the cup heating surface off. You can use hot water to pre-heat the cups instead.

Mains connection cable

Before connecting the coffee machine, make sure that the connection data on the data plate (voltage and frequency) matches the mains electricity supply. This data must correspond in order to avoid the risk of damage to the coffee machine. If in any doubt, consult a qualified electrician.

The required connection data is given on the data plate. The data plate can be seen on the left-hand side of the machine when the drip tray is pulled out.

The machine is supplied with a mains cable with moulded plug for connection to a 50 Hz 220-240 V supply.

The coffee machine must be connected to the mains supply via a suitable switched socket with earthing contact. Connection must comply with national and local safety regulations (BS 7671 in the UK).

The fuse rating must be at least 10 A.

The socket should be next to the appliance and easily accessible where possible.

Do not connect the coffee machine to the mains electricity supply using a multi-socket adapter or an extension lead. These do not guarantee the required safety of the machine (fire risk).

Do not connect the coffee machine to an **off-grid inverter**. These devices are used for autonomous power supply, e.g. a solar power system. Power surges could cause a safety shutdown. This could damage the electronic module.

The coffee machine must not be used with “**energy saving plugs**”. These reduce the amount of energy supplied to the machine, causing it to overheat.

If the mains connection cable is faulty, it must only be replaced by a qualified electrician in order to avoid a hazard.

Conformity declaration

Miele hereby declares that this coffee machine complies with Directive 2014/53/EU.

The complete text of the EU declaration of conformity is available from one of the following internet addresses:

- Products, Download from www.miele.co.uk
- For service, information, operating instructions etc: go to www.miele.co.uk/domestic/customer-information-385.htm and enter the name of the product or the serial number

Frequency band	2.412 GHz – 2.472 GHz
----------------	--------------------------

Maximum transmitting power	< 100 mW
----------------------------	----------

Dimensions

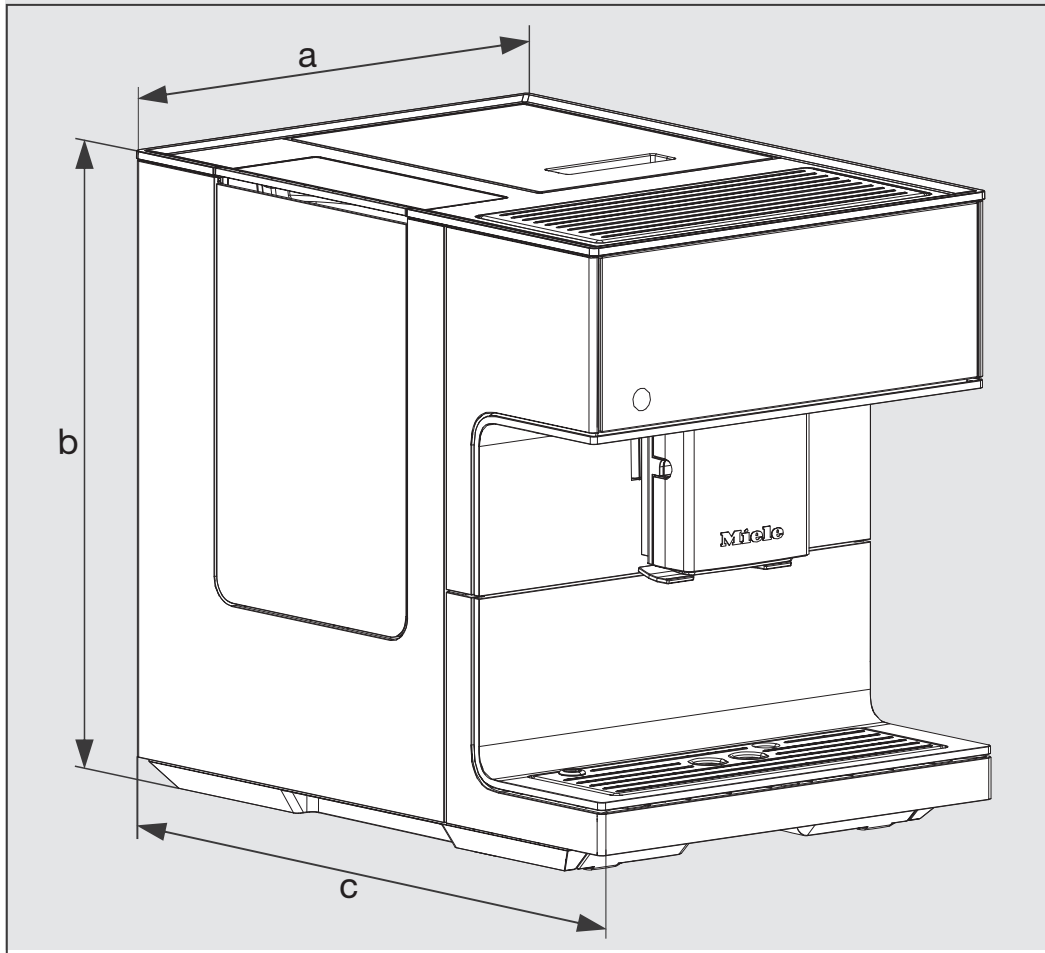

a = 311 mm

b = 397 mm

c = 445 mm

Technical data

Current draw in standby mode (default setting)	< 0.5 Watt
Pump pressure:	max. 15 bar
Through-flow heater:	1 stainless steel thermo block
Dimensions (W x H x D):	311 x 397 x 445 mm
Net weight:	13.4 kg
Connection cable length:	120 cm
Water container capacity:	2.2 l
Coffee bean container capacity:	approx. 500 g
Stainless steel milk flask capacity:	0.5 l
Drip tray capacity:	0.75 l
Waste container capacity:	max. 16 portions of coffee grounds
Central spout:	Height adjustable from 80-160 mm
Grinder:	Conical steel grinder
Grinder setting:	5 settings
Ground coffee amount:	max. 12 g
Frequency band:	2.412 – 2.472 GHz
Max. transmission power	> 100 mW

Conformity declaration

Miele hereby declares that this coffee machine complies with Directive 2014/53/EU.

The complete text of the EU declaration of conformity is available from one of the following internet addresses:

- Products, Download from www.miele.co.uk
- For service, information, operating instructions etc: go to www.miele.co.uk/domestic/customer-information-385.htm and enter the name of the product or the serial number

United Kingdom

Miele Co. Ltd.
Fairacres, Marcham Road
Abingdon, Oxon, OX14 1TW
Tel: 0330 160 6600
Internet: www.miele.com

Miele

Australia

Miele Australia Pty. Ltd.
ACN 005 635 398
ABN 96 005 635 398
1 Gilbert Park Drive
Knoxfield, VIC 3180
Tel: 1300 464 353
Internet: www.miele.com.au

China

Miele (Shanghai) Trading Ltd.
1-3 Floor, No. 82 Shi Men Yi Road
Jing' an District
200040 Shanghai, PRC
Tel: +86 21 6157 3500
Fax: +86 21 6157 3511
E-mail: info@miele.cn,
Internet: www.miele.cn

Miele (Hong Kong) Limited

41/F - 4101, Manhattan Place
23 Wang Tai Road
Kowloon Bay, Hong Kong
Tel: (852) 2610 1025
Fax: (852) 3579 1404
Email:
customerservices@miele.com.hk
Website: www.miele.hk

India

Miele India Pvt. Ltd.
Ground Floor
Copia Corporate Suites
Plot No. 9, Jasola
New Delhi - 110025
Tel: 011-46 900 000
Fax: 011-46 900 001
E-mail: customercare@miele.in
Internet: www.miele.in

Ireland

Miele Ireland Ltd.
2024 Bianconi Avenue
Citywest Business Campus
Dublin 24
Tel: (01) 461 07 10
Fax: (01) 461 07 97
E-Mail: info@miele.ie
Internet: www.miele.ie

Malaysia

Miele Sdn Bhd
Suite 12-2, Level 12
Menara Sapura Kencana
Petroleum
Solaris Dutamas No. 1
Jalan Dutamas 1
50480 Kuala Lumpur, Malaysia
Phone: +603-6209-0288
Fax: +603-6205-3768

New Zealand

Miele New Zealand Limited
IRD 98 463 631
Level 2, 10 College Hill
Freemans Bay, Auckland 1011
New Zealand
Tel: 0800 464 353
Internet: www.miele.co.nz

Singapore

Miele Pte. Ltd.
163 Penang Road
04 - 03 Winsland House II
Singapore 238463
Tel: +65 6735 1191
Fax: +65 6735 1161
E-Mail: info@miele.com.sg
Internet: www.miele.sg

South Africa

Miele (Pty) Ltd
63 Peter Place, Bryanston 2194
P.O. Box 69434, Bryanston 2021
Tel: (011) 875 9000
Fax: (011) 875 9035
E-mail: info@miele.co.za
Internet: www.miele.co.za

Taiwan

K.E. & Kingstone Co., Ltd.
6th Fl., No. 120, Sec. 2
Jianguo N. Rd.
Taipei, Taiwan
TEL: +886 2 2502-7256
FAX: +886 2 2502-3077
E-mail: kenk@kenk.com.tw
Website:
www.kenk.com.tw/ke/miele

Thailand

BHIRAJ TOWER at EmQuartier
43rd Floor Unit 4301-4303
689 Sukhumvit Road
North Klongton Sub-District
Vadhana District
Bangkok 10110, Thailand

United Arab Emirates

Miele Appliances Ltd.
Gold & Diamond Park
Office No. 6-217
Sheikh Zayed Road
P.O. Box 11 47 82 - Dubai
Tel. +971 4 3044 999
Fax. +971 4 3418 852
800-MIELE (64353)
E-Mail: info@miele.ae
Website: www.miele.ae

Manufacturer: Miele & Cie. KG, Carl-Miele-Straße 29, 33332 Gütersloh, Germany

CM 7550

en – GB

M.-Nr. 10 973 180 / 00